

CITY OF MARLBOROUGH MEETING POSTING

Meeting Name: City Council Urban Affairs Committee

Date: March 26, 2019

Time: 5:30 PM

Location: City Council Chamber, 2nd Floor, City Hall, 140 Main Street

RECEIVED
CITY CLERK'S OFFICE
CITY OF MARLBOROUGH

2019 MAR 20 P 12:55

Continued Review:

1. 12-17-2018 – **Order No. 18/19-1007500**: Proposed Zoning Ordinance Amendment, Chapter 650, §15, §17, & §18 – Home Office & Contractor Yards.
-REFER TO URBAN AFFAIRS & PLANNING BOARD
-PUBLIC HEARING: FEBRUARY 11, 2019

New Business:

2. 01-28-2019 – **Order No. 19-1007533**: Proposed Zoning Amendment, to add to Chapter 650 a new section §36, which will create an Executive Residential Overlay District in the Simarano Drive and Cedar Hill Road Area.
-REFER TO URBAN AFFAIRS & PLANNING BOARD
-PUBLIC HEARING: MARCH 11, 2019
3. 11-19-2018 – **Order No. 18/19-1007461 (X18/19-1007423)**: Application for Special Permit from Attorney Sem Aykanian to modify existing Special Permit issued to Main Street Bank, 81 Granger Boulevard on June 22, 2009, Order No. 09-1002152C, to modify permit to allow for an electronic digital display (electronic message board) sign.
-REFER TO URBAN AFFAIRS
-PUBLIC HEARING: FEBRUARY 25, 2019
4. 11-19-2018 – **Order No. 18/19-1007423 (X18/19-1007461)**: Application for LED Sign Special Permit, Main Street Bank, 81 Granger Boulevard.
-REFER TO URBAN AFFAIRS
-PUBLIC HEARING: FEBRUARY 25, 2019

THE LISTING OF TOPICS THAT THE CHAIR REASONABLY ANTICIPATES WILL BE DISCUSSED AT THE MEETING IS NOT INTENDED AS A GUARANTEE OF THE TOPICS THAT WILL HAVE BEEN DISCUSSED. NOT ALL TOPICS LISTED MAY IN FACT BE DISCUSSED, AND OTHER TOPICS NOT LISTED MAY ALSO BE BROUGHT UP FOR DISCUSSION TO THE EXTENT PERMITTED BY LAW.

The public should take due notice that the Marlborough City Council may have a quorum in attendance due to Standing Committees of the City Council consisting of both voting and non-voting members. However, members attending this duly posted meeting are participating and deliberating only in conjunction with the business of the Standing Committee.

Electronic devices, including laptops, cell phones, pagers, and PDAs must be turned off or put in silent mode upon entering the City Council Chamber, and any person violating this rule shall be asked to leave the chamber. Express authorization to utilize such devices may be granted by the President for recordkeeping purposes.



81



Main Street
BANK

DRIVE UP ATM

Vote Today

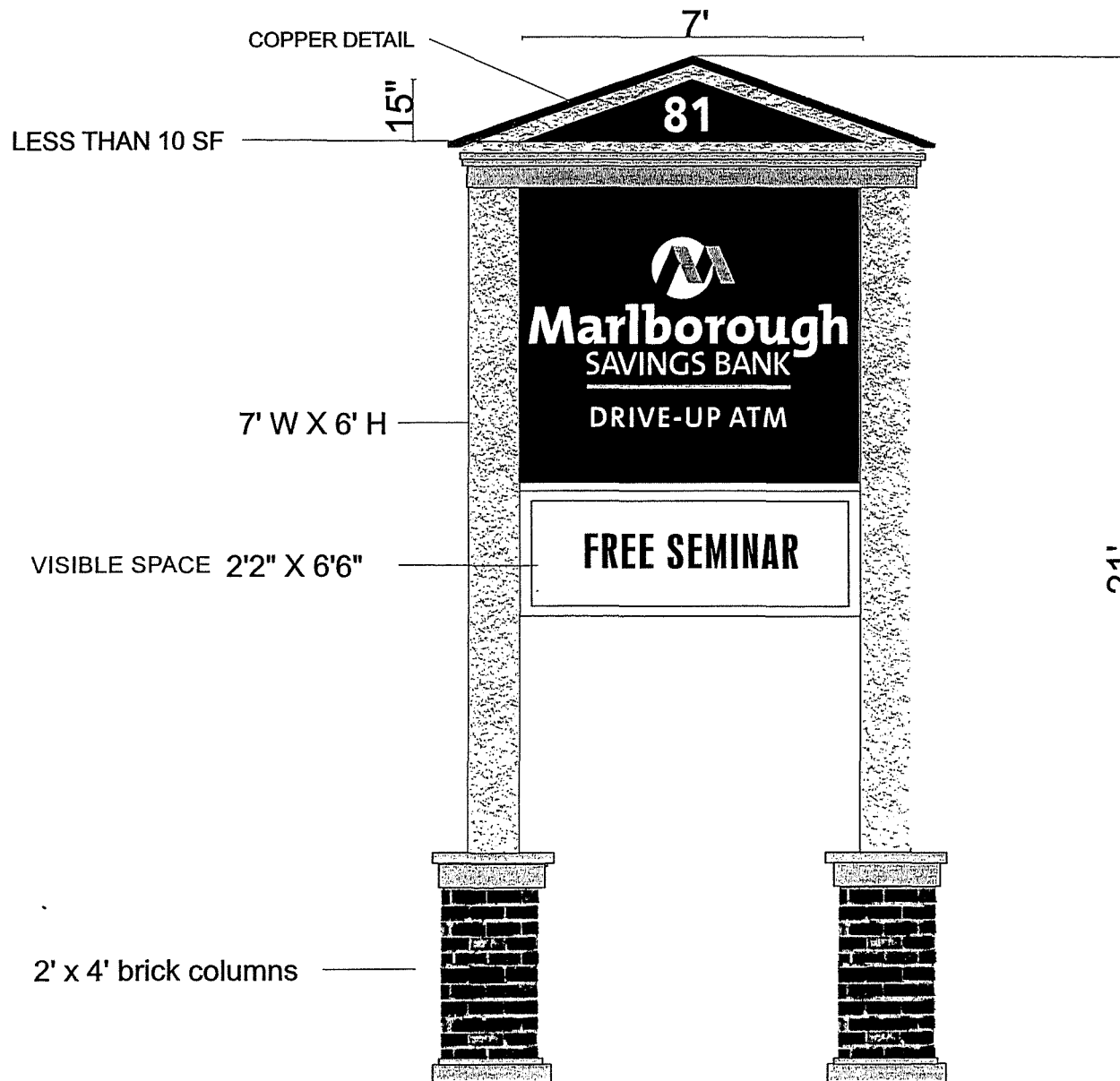

APPROVAL

SIGNATURE & DATE REQUIRED FOR PRODUCTION

Signature

Date

Pylon Sign -
Brick bases w/ stucco columns
Logo Colors: 287c & 381u

Attn: Ellen Dorian
Marlborough Savings Bank
166 Main Street
Marlborough, MA 01752
edorian@marlboroughsavings.com

Expose Signs & Graphics, Inc.
493 Main Street - Northboro, MA 01532
(508)460-1187 - (508)460-1188 fax
Drawn By: Amy F. Clark

GALAXY® GS6 19.8 MM PRODUCT SPECIFICATIONS

The Galaxy GS6 is the best full-feature, high-quality Galaxy series yet. This product provides users a display that runs outstanding graphics and animations using the best contrast in the industry. The 19.8 mm pixel pitch provides a great-looking image and is a popular request among customers.

19.8 MM TECHNICAL SPECIFICATIONS

Character Height:

5.5" (7 pixel font)

Line Spacing:

19.8 mm (0.78")

Pixel Configuration:

Monochrome: 1 red or 1 amber

RGB: 1 red, 1 green, 1 blue

Maximum Brightness:

Monochrome red: 4,500 nits

Monochrome amber: 6,000 nits

RGB: 11,000 nits

Monochrome Color Capability:

4,096 shades of red or amber

Full Color Capability:

RGB: 281 trillion colors

Optimal Viewing Angle:

140 degrees horizontal x 70 degrees vertical

Readability Angle:

160 degrees horizontal x 90 degrees vertical

Min Viewing Distance:

45'

PRODUCT FEATURES

- All sealed components
- Quick connects
- Mounting clips
- High-contrast louvers
- Redundant module signal
- Large sections for fast installation
- Front ventilation on displays less than seven feet tall
- No spreader beam required for displays greater than seven feet tall
- Same module size and cabinet size for all pixel pitches
- Single-step module removal
- Shallow cabinet depth
- Narrow cabinet borders

MODEL NUMBER GUIDE

GS6	-	80	x	200	-	19.8	-	RGB	-	SF
Series		Lines High		Columns Wide		Line Spacing		LED Color Red, Amber, or RGB		Single Face or Two View

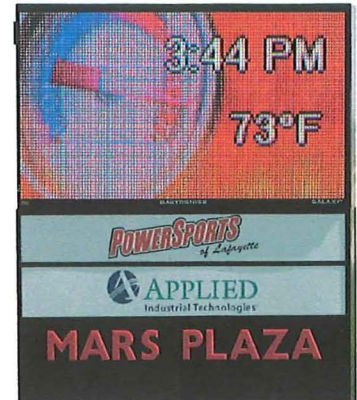

GS6 SERIES SPECIFICATIONS

Estimated LED Lifetime:

100,000+ hours

Contrast Enhancement:

Non-reflective black louvers and module face grooves disperse light

Message Capability:

Text, graphics, logos, basic animation, video clips, multiple font styles, and sizes

Control Software:

Venus® Control Suite

Power:

120, 120/240 VAC Single Phase

Display Dimming:

64 levels (Automatic, scheduled or manual control)

Communication Options:

Ethernet Fiber Optic, Ethernet Bridge Radio, Remote Cellular, Ethernet CAT5

Operating Temperature:

-40°F to 120°F with 99% RH non-condensing

Compliance Information:

UL and cUL Listed, UL-Energy Verified, FCC compliance

Warranty Coverage:

5 years

Galaxy Product Support:

Parts support for 10 years

DISPLAY CONFIGURATIONS



Single-face (SF)
Available in all sizes



Two-view (2V)
Available in all sizes



PIXELS HIGH (AAA)	PIXELS WIDE (BBB)	PIXEL SPACING (CC)
40	150	15.85mm
32	120	19.81mm
24	90	26.42mm

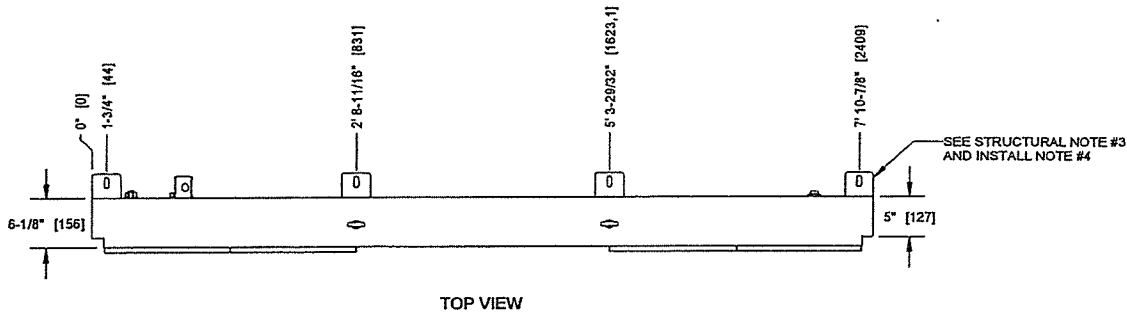

TOP VIEW

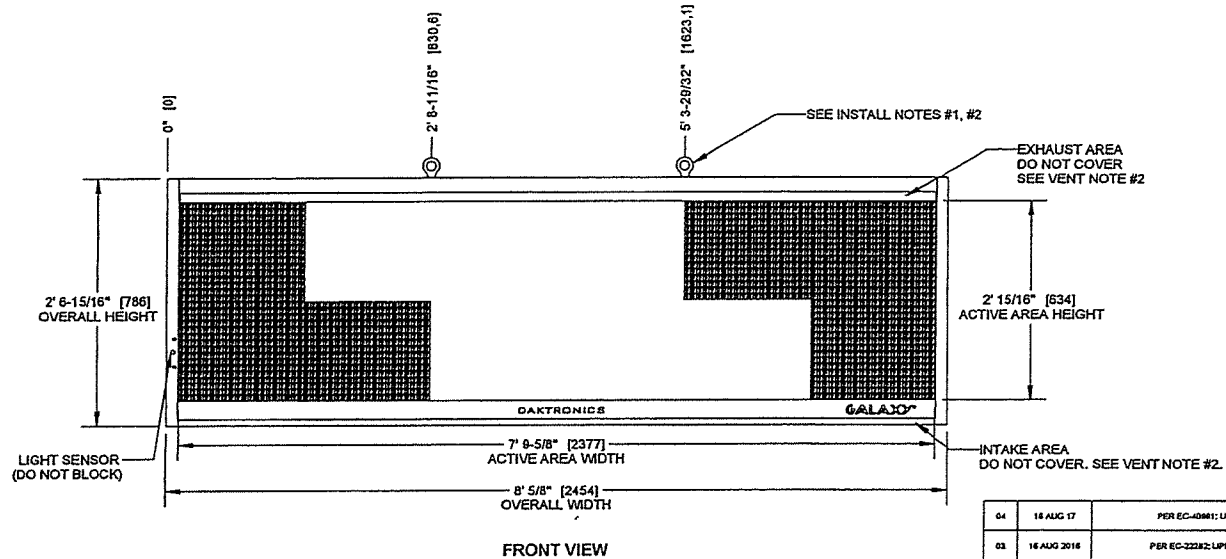

FRONT VIEW

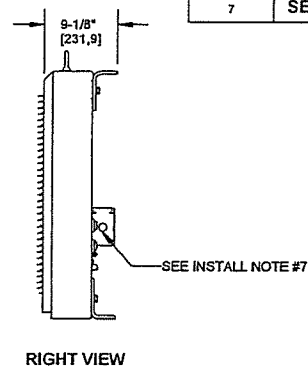

RIGHT VIEW

#	DETAIL	DESCRIPTION
1	DISPLAY	G56 - AAx888-CC (SEE CHART ON TOP LEFT)
2	LED COLOR	RED, AMBER, OR RGB
3	ACTIVE AREA	2' 15/16" [834] X 7' 9-5/8" [2377]
4	OVERALL SIZE	2' 6-15/16" [786] X 8' 5/8" [2454]
5	CABINET	ALUMINUM & STEEL
6	VENTILATION	FRONT
7	ACCESS	SERVICE FROM FRONT OF DISPLAY
8	WEIGHT	150 LBS [68 KG] (APPROX)
9	SHIPPING	SHIPPED AS A SINGLE UNIT
10	DIMENSIONS	FEET AND INCHES [MILLIMETERS]
11	PAINTED	SEMI-GLOSS BLACK

STRUCTURAL RATING		
1	DESIGN WIND PRESSURE "P" (CASE A)	P<=100 PSF (ASD)
2	STANDARD/CODE	IBC 2009/ASCE7-05, IBC 2012/ASCE7-10
3	ALL CLIP ANGLES MUST BE USED TO MOUNT DISPLAY	

POWER RATING PER SINGLE FACE: FOR SIZING ELEC.SERVICE MAX REQ'D SHOWN				
TECHNOLOGY	COLOR	MAX WATTS	120VAC 1PH 50/60Hz (2 WIRES + GND) DOMESTIC	240VAC 1PH 50Hz (2 WIRES + GND) INTERNATIONAL SPECIAL ORDER
			LINE 1 (AMPS)	LINE 1 (AMPS)
G56	RED	434	3.62	1.81
	AMBER	434	3.62	1.81
	RGB	670	5.59	2.79

VENTILATION REQUIREMENTS	
1	DISPLAY RELIES ON VENTILATION TO FUNCTION PROPERLY. INTAKES, LOCATED AT THE FRONT OF THE DISPLAY, MUST BE ABLE TO DRAW IN AIR AT A TEMPERATURE NO GREATER THAN 120° F.
2	IN ORDER TO ENSURE AMBIENT TEMPERATURE AIRFLOW IS MAINTAINED, NO PORTION OF THE VENTILATION OPENINGS ALONG THE FRONT OF THE DISPLAY MAY BE COVERED OR OBSTRUCTED IN ANY WAY.

INSTALL NOTES	
1	IN ORDER TO PRESERVE THE STRUCTURAL INTEGRITY OF THE DISPLAY CABINET, THE 90° ANGLE BETWEEN THE CABINET AND THE LIFTEYES MUST BE MAINTAINED - USING A SPREADER BEAM IS SUGGESTED. ALL EYEBOLTS MUST BE USED WHEN LIFTING.
2	1/2" LIFTEYES TO ASSIST WITH DISPLAY INSTALLATION. LIFTEYES MAY NOT BE USED FOR PERMANENT INSTALLATION. LIFTEYES MAY BE REMOVED.
3	MECHANICAL AND SIGNAL CONNECTIONS OCCUR EXTERNAL TO DISPLAY.
4	CLIP ANGLE FOR MOUNTING. CLIP ANGLES CAN BE ADJUSTED VERTICALLY 1-3/16" AS NEEDED DURING INSTALLATION. CLIP ANGLE CAN BE WELDED OR BOLTED TO STRINGER. ALL CLIP ANGLE LOCATION MUST BE USED.
5	DAKTRONICS IS NOT RESPONSIBLE FOR THE MOUNTING HARDWARE OR THE INTEGRITY OF THE MOUNTING STRUCTURE.
6	DAKTRONICS IS NOT RESPONSIBLE FOR THE MAIN ELECTRICAL DISCONNECT. SEE POWER RATINGS ABOVE.
7	SEE DWG-03097583 FOR SIGNAL & MTG DETAILS

REV	DATE	BY	DESC	APP
04	14 AUG 17		PER EC-1081: UPDATED POWER SPECS	RAB 1835
03	16 AUG 2016		PER EC-2282: UPDATED DRAWING LAYOUT	DJO 16434
02	09 MAY 16		UPDATED GALAXY LABEL	BA6 18436

D THE CONCEPTS EXPRESSED AND DETAILS SHOWN ON THIS DRAWING ARE CONFIDENTIAL AND PROPRIETARY. DO NOT REPRODUCE OR ANY MANNER WITHOUT THE EXPRESS WRITTEN CONSENT OF DAKTRONICS, INC. OR ITS WHOLLY OWNED SUBSIDIARIES. COPYRIGHT 2017 DAKTRONICS, INC. (USA)

PROJECT: GALAXY G56 SERIES
 TITLE: SHOP DWG, G56-R, 2' 7"x8' 1" (2x6 MODS)
 DATE: 14-AUG-17 DIM UNITS: INCHES (MILLIMETERS)
 SCALE: 1/15 DO NOT SCALE DRAWING SHEET 1 OF 1 REV 04
 DESIGN: TWHITEH JOB NO. P1817
 DRAWN: DCOSTRAA P1817 E-07-B 3111193



IN CITY COUNCIL

Marlborough, Mass., JANUARY 7, 2019

ORDERED:

That there being no objection thereto set **MONDAY, FEBRUARY 25, 2019** as **DATE TO RESCHEDULE PUBLIC HEARING** On the Application for Special Permit from Attorney Sem Aykanian to modify existing Special Permit issued to Main Street Bank, 81 Granger Boulevard on June 22, 2009, Order No. 09-1002152C, to modify permit to allow for an electronic digital display (electronic message board) sign, be and is herewith refer to **URBAN AFFAIRS COMMITTEE & ADVERTISE.**

Councilor Delano recused.

Ninety days after public hearing is 05/26/19 which falls on a Sunday, therefore 05/27/19 would be considered the 90th day.

ADOPTED

ORDER NO. 18-1007461A
X 09-1002152C
X 12-1004081C

**CITY OF MARLBOROUGH
OFFICE OF THE CITY CLERK**

APPLICATION TO CITY COUNCIL FOR ISSUANCE OF SPECIAL PERMIT

1. Name and address of Petitioner or Applicant:

Main Street Bank, 81 Granger Boulevard, Marlborough, MA

2. Specific Location of property including Assessor's Plate and Parcel Number.

81 Granger Boulevard / Map 70 / Parcel 152

3. Name and address of owner of land if other than Petitioner or Applicant:

Fitzpatrick Family Investment Trust, 3 Reservoir Lane, Upton, MA

4. Legal interest of Petitioner or Applicant (owner, lessee, prospective owner, etc.)
Owner and Lessee

5. Specific Zoning Ordinance under which the Special Permit is sought: N/A - Petitioner seeks amendment to Special Permit allowed by City Council Order No. 09-1002152C, Article _____ Section _____ Paragraph _____ Sub-paragraph _____ attached hereto.

6. Zoning District in which property in question is located:

Business Zone

7. Specific reason(s) for seeking Special Permit - Amendment

Petitioner seeks to amend the existing Special Permit by removing Condition #4 that prohibits signs on the Site, which have moving parts, message boards, LCD or equiv. features; and in its place inserting a new Condition #4 comporting with §526-13, entitled "Electronic Message Center Signs and Digital Display Sign", see attached the proposed sign for this location.

8. List of names and addresses of abutter. SEPARATE SHEET ATTACHED

PETITION IS HEREBY MADE FOR THE ISSUANCE OF A SPECIAL PERMIT BY THE CITY COUNCIL OF THE CITY OF MARLBOROUGH AND IS BASED ON THE WITHIN PETITION OR APPLICATION AS FILED HERewith AND MADE PART OF SAID PETITION.

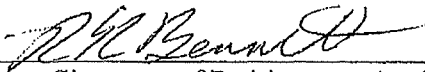

Signature of Petitioner or Applicant

Address: 81 Granger Boulevard
Marlborough, MA

Telephone No. 508-460-4150

Date: 11/13/2018

LIST OF NAMES AND ADDRESS OF ABUTTERS
AS REQUESTED ON THE APPLICATION FOR SPECIAL PERMIT OF:

Main Street Bank

(Name of Petitioner)

FOR THE ISSUANCE OF SPECIAL PERMIT BY THE CITY COUNCIL OF THE CITY OF MARLBOROUGH UNDER CHAPTER 650, ZONING, OF THE CODE OF THE CITY OF MARLBOROUGH.

(Abutters as defined in §650-59, Section 4H, **Powers and Procedure of Special-Permit Granting Authorities**)

ATTACHED HERETO



IN CITY COUNCIL

Marlborough, Mass., JANUARY 7, 2019

ORDERED:

That there being no objection thereto set **MONDAY, FEBRUARY 25, 2019** as **DATE TO RESCHEDULE PUBLIC HEARING** On the Application for Sign Special Permit, Main Street Bank, 81 Granger Boulevard Marlborough to operate an electronic message center sign at its bank located at 81 Granger Boulevard, be and is herewith refer to **URBAN AFFAIRS COMMITTEE & ADVERTISE.**

Councilor Delano recused.

ADOPTED

18/19

ORDER NO. 18-1007423B
X 18-1007461

8



City of Marlborough BUILDING DEPARTMENT

140 Main Street
Marlborough, Massachusetts 01752
Tel. (508) 460-3776 Facsimile (508) 460-3736
building_dept@marlborough-ma.gov

RECEIVED
CITY CLERK'S OFFICE
CITY OF MARLBOROUGH
2018 NOV 15 A 10:48
JEFFREY COOKE, C.B.O.
BUILDING COMMISSIONER
PATRICK DAHLGREN
ASSISTANT BUILDING
COMMISSIONER
WILLIAM PAYNTON
LOCAL BUILDING INSPECTOR
RICHARD DESIMONE
PLUMBING & GAS INSPECTOR
JOHN CAIN
WIRING INSPECTOR

November 14, 2018

Edward Clancy
City Council President
City Hall
Marlborough, MA 01752

*Weland received
1/17/19
ADV
JA 2*

RE: Order No.18-1007423: Application for LED Sign Special Permit for Main Street Bank, 81 Granger Boulevard

Dear President and Members:

Per Order of the City Council dated October 15, 2018, attached herein together with the EMB (electronic message board) sign special permit application, I have reviewed the original special permit decision for the drive through window at 81 Granger Boulevard and find a modification is required to move forward with the sign special permit application.

Toward that end, MSB has filed an application to amend the special permit decision by removing language that prohibits message board signs.

The Special Permit modification application is before you this evening and you may schedule both applications for advertisement and public hearings as required.

Sincerely,

Jeffrey Cooke, C.B.O.
Building Commissioner
Zoning Enforcement Officer

JC/kb

Mission Statement

To promote the safe and compatible development of the community through the fair and consistent enforcement of the building codes and zoning ordinances



City of Marlborough

RECEIVED
CITY CLERK'S OFFICE
CITY OF MARLBOROUGH

2018 OCT -3 A 10:00

MARLBOROUGH CITY COUNCIL

RECEIVED
OCT 03 2018
BY _____ 18

LED SIGN PERMIT APPLICATION TO MARLBOROUGH CITY COUNCIL

LED SIGN SPECIAL PERMIT

*Delano
revised
Building Commr
+ to Amend
S.P.*

INSTRUCTIONS: This application must be filled out and submitted to the City Council. Applicant must attach to this application a copy of the Building Commissioner's decision detailing the requirements and reason for City Council action. This application form must be signed by the applicant or his authorized agent (and the owner of the property if the owner is not the applicant) prior to submittal to the City Council.

1. Location of the property where sign is located: Street and Number:

81 Granger Blvd

*2157 - 3/5/09
12-4081*

2. What other signs exist on the property (type, size, location):

Main Bylon 76" x 96" Internally luminated
Building Sign 60" x 60" " " Under the dome
Exterior door bands - front entrance w/ hours of operation 12" x 29-7"
Drive-up band w/ hours on drive-up window 7" x 66-75"

3. Are there other signs on the property of similar type to what is requested in the LED Sign Permit Application? If so, please state size and location.

No

4. Names of business or activity applying for sign:

Main Street Bank

5. Applicant:

Main Street Bank

Street/City/Zip Code:

81 Granger Blvd. Marlborough, Ma. 01752

6. Building Owner:

Same
Street/City/Zip Code:

7. Contact Information. Please provide an E-mail address as well as Business and Mobile telephone numbers.

Building Owner.

E-mail: rbennett@bankmainstreet.com Business: 508-460-4150 Mobile: _____

Agent/Owner of Business where sign will be located.

E-mail: Same Business: _____ Mobile: _____

Applicant.

E-mail: Same Business: _____ Mobile: _____

8. Applicant is (please check).

Business Owner: Tenant: _____ Other (describe): _____

Required Attachments

Description of Sign and Plan: Please include letter from Building Commissioner noted above together with plans and renderings to assist the City Council in its deliberations on the application for a Sign Special Permit. Other pertinent information may be submitted with this application and may be required by the City Council.

The City Council will hold a Public Hearing on the Sign Special Permit Application. Applicant shall pay for advertising of Hearing. Applicant shall obtain a certified abutters' list from the Assessors' Office to attach to this application. Applicant shall notify abutters of Hearing and provide proof of mailing prior to the Hearing.

After the close of the Public Hearing, Applicant shall submit a draft Sign Special Permit Decision to the City Council, through the appropriate City Council Committee. A sample decision will be provided to Applicant upon request.

RK Bennett, CEO
Applicant Signature

10/3/18
Date

Property Owner Signature

Date

NOTE: New Electronic Message Center Signs or Digital Display Signs may not be erected until the City Council Sign Special Permit has been granted and building permit has been issued by the Building Department.

DEPARTMENT HEAD

COMMENTS

MAIN STREET BANK
APPLICATION TO MODIFY
SPECIAL PERMIT

&

APPLICATION FOR
ELECTRONIC MESSAGE
BOARD SIGN

IN URBAN AFFAIRS
MARCH 26, 2019

City Council

From: Jeffrey Cooke
Sent: Thursday, March 21, 2019 7:15 PM
To: City Council
Subject: RE: FOR INPUT--URBAN AFFAIRS TO MEET NEXT TUESDAY: TO MANAGERS FOR COMMENT: Modification of Special has Permit and Sign Permit Main Street Bank (MSB), Granger Blvd

In regards to the signage request of MSB, I have no concerns or comments

Jeffrey Cooke, C.B.O.
Building Commissioner
City of Marlborough, MA
508-460-3776

Mission Statement

To promote the safe and compatible development of the community through fair and consistent enforcement of building codes and zoning ordinances

-----Original Message-----

From: City Council
Sent: Thursday, March 21, 2019 7:00 PM
To: Jeffrey Cooke <jcooke@marlborough-ma.gov>; Priscilla Ryder <pryder@marlborough-ma.gov>; Thomas DiPersio <tdipersio@marlborough-ma.gov>; Kevin Breen <kbreen@marlborough-ma.gov>; David Giorgi <dgiorgi@marlborough-ma.gov>; Cathleen Liberty <cliberty@marlborough-ma.gov>
Subject: FOR INPUT--URBAN AFFAIRS TO MEET NEXT TUESDAY: TO MANAGERS FOR COMMENT: Modification of Special has Permit and Sign Permit Main Street Bank (MSB), Granger Blvd

Thanks for your input, even if no comment.
KB

-----Original Message-----

From: City Council
Sent: Tuesday, March 5, 2019 1:17 PM
To: Priscilla Ryder <pryder@marlborough-ma.gov>; Jeffrey Cooke <jcooke@marlborough-ma.gov>; Thomas DiPersio <tdipersio@marlborough-ma.gov>; Kevin Breen <kbreen@marlborough-ma.gov>; David Giorgi <dgiorgi@marlborough-ma.gov>; Cathleen Liberty <cliberty@marlborough-ma.gov>
Subject: TO MANAGERS FOR COMMENT: Modification of Special has Permit and Sign Permit Main Street Bank (MSB), Granger Blvd

-----Original Message-----

From: Elena Kristie <EKristie@aykanianlaw.com>
Sent: Tuesday, March 5, 2019 12:41 PM
To: Karen Boule <kboule@marlborough-ma.gov>
Subject: RE: Modification of Special has Permit and Sign Permit

Good afternoon, Karen,

City Council

From: David Giorgi
Sent: Thursday, March 21, 2019 7:33 PM
To: City Council
Cc: Jeffrey Cooke; Priscilla Ryder; Thomas DiPersio; Kevin Breen; Cathleen Liberty
Subject: Re: FOR INPUT--URBAN AFFAIRS TO MEET NEXT TUESDAY: TO MANAGERS FOR COMMENT: Modification of Special has Permit and Sign Permit Main Street Bank (MSB), Granger Blvd

Good evening,
The Police Department does not have any comments pertaining to this modification.
Thank you,
D. Giorgi

Sent from my iPhone

> On Mar 21, 2019, at 7:01 PM, City Council <citycouncil@marlborough-ma.gov> wrote:

>

> Thanks for your input, even if no comment.

> KB

>

> -----Original Message-----

> From: City Council

> Sent: Tuesday, March 5, 2019 1:17 PM

> To: Priscilla Ryder <pryder@marlborough-ma.gov>; Jeffrey Cooke

> <jcooke@marlborough-ma.gov>; Thomas DiPersio

> <tdipersio@marlborough-ma.gov>; Kevin Breen

> <kbreen@marlborough-ma.gov>; David Giorgi

> <dgiorgi@marlborough-ma.gov>; Cathleen Liberty

> <cliberty@marlborough-ma.gov>

> Subject: TO MANAGERS FOR COMMENT: Modification of Special has Permit

> and Sign Permit Main Street Bank (MSB), Granger Blvd

>

> -----Original Message-----

> From: Elena Kristie <EKristie@aykanianlaw.com>

> Sent: Tuesday, March 5, 2019 12:41 PM

> To: Karen Boule <kboule@marlborough-ma.gov>

> Subject: RE: Modification of Special has Permit and Sign Permit

>

> Good afternoon, Karen,

>

> Sem forwarded me your e-mail. We were just working on the decision drafts. Please see attached for your review and reference. The only thing I'm waiting on from Main Street Bank, is the name of the installer for the sign.

>

> Please let us know when it's scheduled with Urban Affairs. Also, Sem will be on vacation 3/13 - 3/18, so we ask that those dates are taken into account.

>

> Regards,

>

City Council

From: Kevin Breen
Sent: Friday, March 22, 2019 9:34 AM
To: City Council
Subject: RE: FOR INPUT--URBAN AFFAIRS TO MEET NEXT TUESDAY: TO MANAGERS FOR COMMENT: Modification of Special has Permit and Sign Permit Main Street Bank (MSB), Granger Blvd

Good Morning Karen:

In response to your email, please pass along to city counselors that we here at MFD have no objection to the installation of the electronic message sign at Main Street bank.

Thank you,

KJB

Kevin J. Breen, Fire Chief
Marlborough Fire Department
215 Maple Street
Marlborough, MA 01752
(508) 624-6986

-----Original Message-----

From: City Council
Sent: Thursday, March 21, 2019 7:00 PM
To: Jeffrey Cooke <jcooke@marlborough-ma.gov>; Priscilla Ryder <pryder@marlborough-ma.gov>; Thomas DiPersio <tdipersio@marlborough-ma.gov>; Kevin Breen <kbreen@marlborough-ma.gov>; David Giorgi <dgiorgi@marlborough-ma.gov>; Cathleen Liberty <cliberty@marlborough-ma.gov>
Subject: FOR INPUT--URBAN AFFAIRS TO MEET NEXT TUESDAY: TO MANAGERS FOR COMMENT: Modification of Special has Permit and Sign Permit Main Street Bank (MSB), Granger Blvd

Thanks for your input, even if no comment.

KB

-----Original Message-----

From: City Council
Sent: Tuesday, March 5, 2019 1:17 PM
To: Priscilla Ryder <pryder@marlborough-ma.gov>; Jeffrey Cooke <jcooke@marlborough-ma.gov>; Thomas DiPersio <tdipersio@marlborough-ma.gov>; Kevin Breen <kbreen@marlborough-ma.gov>; David Giorgi <dgiorgi@marlborough-ma.gov>; Cathleen Liberty <cliberty@marlborough-ma.gov>
Subject: TO MANAGERS FOR COMMENT: Modification of Special has Permit and Sign Permit Main Street Bank (MSB), Granger Blvd

-----Original Message-----

From: Elena Kristie <EKristie@aykanianlaw.com>
Sent: Tuesday, March 5, 2019 12:41 PM
To: Karen Boule <kboule@marlborough-ma.gov>

City Council

From: Priscilla Ryder
Sent: Friday, March 22, 2019 11:22 AM
To: City Council
Subject: RE: FOR INPUT--URBAN AFFAIRS TO MEET NEXT TUESDAY: TO MANAGERS FOR COMMENT: Modification of Special has Permit and Sign Permit Main Street Bank (MSB), Granger Blvd

Hi Karen,

I have no comments on this sign permit request.

Thank you!

Priscilla Ryder
Conservation Officer
140 Main St. City Hall; Marlborough, MA 01752
Ph: 508-460-3768 ; pryder@marlborough-ma.gov

-----Original Message-----

From: City Council
Sent: Thursday, March 21, 2019 7:00 PM
To: Jeffrey Cooke <jcooke@marlborough-ma.gov>; Priscilla Ryder <pryder@marlborough-ma.gov>; Thomas DiPersio <tdipersio@marlborough-ma.gov>; Kevin Breen <kbreen@marlborough-ma.gov>; David Giorgi <dgiorgi@marlborough-ma.gov>; Cathleen Liberty <cliberty@marlborough-ma.gov>
Subject: FOR INPUT--URBAN AFFAIRS TO MEET NEXT TUESDAY: TO MANAGERS FOR COMMENT: Modification of Special has Permit and Sign Permit Main Street Bank (MSB), Granger Blvd

Thanks for your input, even if no comment.
KB

-----Original Message-----

From: City Council
Sent: Tuesday, March 5, 2019 1:17 PM
To: Priscilla Ryder <pryder@marlborough-ma.gov>; Jeffrey Cooke <jcooke@marlborough-ma.gov>; Thomas DiPersio <tdipersio@marlborough-ma.gov>; Kevin Breen <kbreen@marlborough-ma.gov>; David Giorgi <dgiorgi@marlborough-ma.gov>; Cathleen Liberty <cliberty@marlborough-ma.gov>
Subject: TO MANAGERS FOR COMMENT: Modification of Special has Permit and Sign Permit Main Street Bank (MSB), Granger Blvd

-----Original Message-----

From: Elena Kristie <EKristie@aykanianlaw.com>
Sent: Tuesday, March 5, 2019 12:41 PM
To: Karen Boule <kboule@marlborough-ma.gov>
Subject: RE: Modification of Special has Permit and Sign Permit

Good afternoon, Karen,

City Council

From: Cathleen Liberty
Sent: Friday, March 22, 2019 12:20 PM
To: City Council
Subject: RE: FOR INPUT--URBAN AFFAIRS TO MEET NEXT TUESDAY: TO MANAGERS FOR COMMENT: Modification of Special has Permit and Sign Permit Main Street Bank (MSB), Granger Blvd

Hi, it may be in the junk, more and more e-mails are being sent there.

The BOH does not have a comment on the issue.

Thank you for resending this!

Cathleen

-----Original Message-----

From: City Council
Sent: Friday, March 22, 2019 12:12 PM
To: Cathleen Liberty <cliberty@marlborough-ma.gov>
Subject: FW: FOR INPUT--URBAN AFFAIRS TO MEET NEXT TUESDAY: TO MANAGERS FOR COMMENT: Modification of Special has Permit and Sign Permit Main Street Bank (MSB), Granger Blvd

Cathleen--Sent twice as shown below...on March 5 and early evening yesterday. That's why I emailed you directly. Must be a problem with email. I could be in your junk folder! HaHa.

It has happened to me on several occasions...

Thanks and NP.

KB

-----Original Message-----

From: City Council
Sent: Thursday, March 21, 2019 7:00 PM
To: Jeffrey Cooke <jcooke@marlborough-ma.gov>; Priscilla Ryder <pryder@marlborough-ma.gov>; Thomas DiPersio <tdipersio@marlborough-ma.gov>; Kevin Breen <kbreen@marlborough-ma.gov>; David Giorgi <dgiorgi@marlborough-ma.gov>; Cathleen Liberty <cliberty@marlborough-ma.gov>
Subject: FOR INPUT--URBAN AFFAIRS TO MEET NEXT TUESDAY: TO MANAGERS FOR COMMENT: Modification of Special has Permit and Sign Permit Main Street Bank (MSB), Granger Blvd

Thanks for your input, even if no comment.

KB

-----Original Message-----

From: City Council
Sent: Tuesday, March 5, 2019 1:17 PM
To: Priscilla Ryder <pryder@marlborough-ma.gov>; Jeffrey Cooke <jcooke@marlborough-ma.gov>; Thomas DiPersio <tdipersio@marlborough-ma.gov>; Kevin Breen <kbreen@marlborough-ma.gov>; David Giorgi <dgiorgi@marlborough-ma.gov>; Cathleen Liberty <cliberty@marlborough-ma.gov>
Subject: TO MANAGERS FOR COMMENT: Modification of Special has Permit and Sign Permit Main Street Bank (MSB), Granger Blvd

Draft Decisions

Submitted by:

Attorney Aykanian

1. Decision to Modify Existing
Special Permit (Operation of
Drive Through Window)

&

2. Decision to Operate an
Electronic Message Board
Sign

IN CITY COUNCIL

ORDERED:

DECISION ON A SPECIAL PERMIT

IN CITY COUNCIL

Special Permit
Main Street Bank
Order No. #18/19-1007461A
X09-1002152C
X12-1004081C

DECISION ON A SPECIAL PERMIT CITY COUNCIL ORDER NO. 18/19-1007461A

The City Council of the City of Marlborough hereby GRANTS the application to amend a Special Permit to Main Street Bank (the "Applicant") for the property located at 81 Granger Boulevard, Marlborough, Massachusetts, as provided in this Decision and subject to the following Findings of Fact and Conditions.

FINDINGS OF FACT AND RULING

1. The Applicant is the owner and lessee of the property located at 81 Granger Boulevard, Marlborough, Massachusetts, as shown on the Marlborough Assessors Maps as Map 70, Parcels 152 (the "Site").
2. The Site is subject to a special permit issued by the City Council of the City of Marlborough dated June 22, 2009, Order No. 09-1002152C (the "Original Special Permit," attached hereto as Exhibit A).
3. In light of the amendment to the City Code creating § 526-13 entitled, Electronic Message Center Signs and Digital Display Signs, the Applicant seeks to amend the Original Special Permit by removing Condition #7 which prohibits signs on the Site which have moving parts, message boards, LCDs or equivalent features; and inserting in place thereof a new Condition #7 comporting with § 526-13 (the "Application").
4. In connection with the Application, the Applicant has submitted a certified list of abutters, filing fees, and the existing approved site plan for the Site entitled, "Permit Site Plan, Marlborough Savings Bank", prepared for Marlborough Savings Bank, drawn by Hancock Associates, 315 Elm Street, Marlborough, MA, dated March 5, 2009 (the "Plans").

5. The site plan was certified by the acting City Planner for the City of Marlborough as having complied with Rule 4, items (a) through (m), of the Rules and Regulations promulgated by the City Council for the issuance of a Special Permit.
6. Pursuant to the Rules and Regulations of the City Council for the City of Marlborough and applicable statutes of the Commonwealth of Massachusetts, the City Council established a date for public hearing on the Application and the City Clerk for the City of Marlborough caused notice of the same to be advertised and determined that notice of the same was provided to abutters entitled thereto in accordance with applicable regulations and law.
7. The Marlborough City Council, pursuant to Massachusetts General Laws, Chapter 40A, held a public hearing on the application on February 25, 2019.
8. The Applicant, through its representatives, presented testimony at the public hearing detailing the Application. No individual in attendance at the public hearing spoke in opposition to the Application.

**BASED ON THE ABOVE, THE CITY COUNCIL MAKES THE FOLLOWING
FINDINGS AND TAKES THE FOLLOWING ACTIONS**

- A. The Applicant has complied with all Rules and Regulations promulgated by the Marlborough City Council as they pertain to special permit applications.
- B. The City Council finds that the proposed use of the Site is an appropriate use and in harmony with the general purpose and intent of the Zoning Ordinance of the City of Marlborough when subject to the appropriate terms and conditions as provided herein. The City Council makes these findings subject to the completion and adherence by the Applicant, its successors and/or assigns, to the conditions more fully set forth herein.
- C. The City Council, pursuant to its authority under Massachusetts General Laws Chapter 40A and the Zoning Ordinance of the City of Marlborough, hereby GRANTS the Applicant an Amended Special Permit, SUBJECT TO THE FOLLOWING CONDITIONS, which conditions shall be binding on the Applicant, its successors and/or assigns:
 1. The Original Special Permit is amended by removing Condition #7 in its entirety and inserting in place thereof the following:
 - 7) The location and design of any signage on the Site shall be reviewed and approved by the City of Marlborough in accordance with § 526-13 entitled, Electronic Message Center Signs and Digital Display Signs, as set forth in the City Code of the City of Marlborough.
 2. In accordance with the provisions of M.G.L. c. 40A, § 11, the Applicant, its successors and/or assigns shall, at its expense, record this Amended Special Permit in the Middlesex South Registry of Deeds after the City Clerk has certified that the twenty-day period for appealing this Amended Special Permit has elapsed with no appeal having been filed, and before the Applicant, its successors and/or assigns, has applied to the

Building Commissioner for any building permit that may be required concerning the Sign. The Applicant, its successors and/or assigns shall also furnish proof of recording to the City Solicitor's Office and the City Council immediately subsequent to recording.

3. Except as amended by this Decision, the Original Special Permit remains in full force and effect.

Yea: _____ - Nay: _____ - Absent: _____

ADOPTED

In City Council

Order No. 18/19-1007461A

Adopted: _____ 2019

Approved by Mayor

Arthur Vigeant

Date: _____ 2019

A TRUE COPY

ATTEST: _____ City Clerk

EXHIBIT A

ORDERED:

DECISION ON A SPECIAL PERMIT

IN CITY COUNCIL

Special Permit
Main Street Bank
Order No. 18/19-1007423B

**DECISION ON A SIGN ORDINANCE SPECIAL PERMIT
CITY COUNCIL ORDER NO. 18/19-1007423B**

The City Council of the City of Marlborough hereby GRANTS the application for a Sign Ordinance Special Permit to Main Street Bank (the "Applicant") for the property located at 81 Granger Boulevard, Marlborough, Massachusetts, as provided in this Decision and subject to the following Procedural Findings and Findings of Facts and Conditions.

FINDINGS OF FACT AND RULING

1. The Applicant is the owner and lessee of the property located at 81 Granger Boulevard, Marlborough, Massachusetts, as shown on the Marlborough Assessors Maps as Map 70, Parcel 152 (the "Site").
2. The Applicant seeks a Sign Ordinance Special Permit, pursuant to Section 526-13 of the Code of the City of Marlborough entitled, Electronic Message Center Signs and Digital Display Signs (the "EMC and Digital Display Sign Ordinance"), to operate an electronic message center sign (the "Sign") at the Site (the "Application").
3. The Sign is a 31-inch by 97-inch double-faced full color electronic message center (EMC) sign, with a display area of 16.32 square feet. The Sign is to be located below an internally-illuminated sign at the premises.
4. The Sign installer is

5. In connection with the Application, the Applicant has submitted schematic designs of the Site and a sketch plan showing the location of the Sign on the Site.
6. The Marlborough City Council held a public hearing on the Application on February 25, 2019.
7. The Applicant, through its representatives, presented testimony at the public hearing detailing the Sign. No individual in attendance at the public hearing spoke in opposition to the Sign.

BASED ON THE ABOVE, THE CITY COUNCIL MAKES THE FOLLOWING FINDINGS AND TAKES THE FOLLOWING ACTIONS

- A. The Applicant has complied with all rules and regulations promulgated by the Marlborough City Council as they pertain to application for a special permit under the EMC and Digital Display Sign Ordinance.
- B. The City Council finds that the Sign complies with the standards set forth in Section 526-13.B of the EMC and Digital Display Sign Ordinance.
- C. The City Council finds, pursuant to Section 526-13.B(16) of the EMC and Digital Display Sign Ordinance, that: all other signage on the Site is in compliance with zoning requirements; the Sign does not create unnecessary visual clutter or constitute signage overload for the lot or surrounding neighborhood or street; the Sign does not substantially block visibility of signs on abutting lots; the Sign does not substantially block solar access of, or the view from, windows of residential dwellings on abutting lots; the proposed illumination is appropriate to the Site and is appropriately located with respect to the character of the surrounding neighborhood; the scale and/or location of the Sign is appropriate; and the dimensions of the Sign comply with the area limitations of the EMC and Digital Display Sign Ordinance, as permitted by the Variances.
- D. The City Council, pursuant to its authority under the EMC and Digital Display Sign Ordinance, hereby GRANTS the Applicant a special permit for the Sign, SUBJECT TO THE FOLLOWING CONDITIONS, which conditions shall be binding on the Applicant, its successors and/or assigns:
 - 1. The Sign shall be operated in accordance with the EMC and Digital Display Sign Ordinance of the City of Marlborough.

Yea: _____ - Nay: _____ - Absent: _____

ADOPTED
In City Council
Order No. 18/19-1007423B
Adopted: _____ 2019

Approved by Mayor
Arthur Vigeant
Date: _____ 2019

A TRUE COPY
ATTEST: _____ City Clerk

PUBLIC HEARING
TRANSCRIPTS

SPECIAL PERMIT TO
MODIFY A SPECIAL
PERMIT

&

SPECIAL PERMIT TO
OPERATE AN ELECTRONIC
MESSAGE BOARD SIGN



IN CITY COUNCIL

Marlborough, Mass., FEBRUARY 25, 2019

ORDERED:

That the PUBLIC HEARING On the Application for Special Permit from Attorney Sem Aykanian to modify existing Special Permit issued to Main Street Bank, 81 Granger Boulevard on June 22, 2009, Order No. 09-1002152C, to modify permit to allow for an electronic digital display (electronic message board) sign, Order No. 18/19-1007461A, X09-1002152C, X12-1004081C, all were heard who wish to be heard, hearing closed at 8:14 PM.

Councilor Delano recused.

Councilors Present: Doucette, Dumais, Tunnera, Irish, Clancy, Landers, Juaire, Oram, Ossing & Robey.

PUBLIC SPEAKING IN FAVOR

Attorney Sem Aykanian, 74 Main Street, Marlborough, appeared on behalf of Main Street Bank on their request to modify their special permit to allow for an electronic message board sign at their Granger Boulevard location. He explained their first request is to amend their existing special permit, which prohibits electronic signs, and then they require a special permit under the electronic sign ordinance. When the original special permit was granted, it was a different atmosphere with respect to electronic signs. Through the years, the signs have become an essential part of the business for many banks. He described how the bank has become integrated into the neighborhood and has been a good and responsible neighbor to those around them.

There is no one else speaking in favor. That part of the Public Hearing is closed.

QUESTIONS FROM THE PUBLIC

There are no questions from the public. That part of the Public Hearing is closed.

PUBLIC SPEAKING IN OPPOSITION

There is no one speaking in opposition. That part of the Public Hearing is closed.

QUESTIONS FROM THE CITY COUNCIL

✓ Councilor Juaire stated this would be taken up in the Urban Affairs Committee shortly.

There are no further questions from members of City Council. That part of the Public Hearing is closed.

That ends the entire Public Hearing. This is currently in the Urban Affairs Committee.

ADOPTED

ORDER NO. 18/19-1007461B

X 09-1002152C

X 12-1004081C



IN CITY COUNCIL

Marlborough, Mass., FEBRUARY 25, 2019

ORDERED:

That the PUBLIC HEARING On the Application for Sign Special Permit, from Main Street Bank, 81 Granger Boulevard to operate an electronic message center sign at its bank located at 81 Granger Boulevard, Order No. 18/19-1007423B, X18-1007461A, all were heard who wish to be heard, hearing closed at 8:16 PM.

Councilor Delano recused.

Councilors Present: Doucette, Dumais, Tunnera, Irish, Clancy, Landers, Juair, Oram, Ossing & Robey.

PUBLIC SPEAKING IN FAVOR

Attorney Sem Aykanian, 74 Main Street, Marlborough, appeared on behalf of Main Street Bank on their request to operate an electronic message center sign at its bank located at Granger Boulevard. He reiterated his previous statements for the public hearing on the application for a special permit to modify the existing Special Permit issued to Main Street Bank to allow for an electronic digital display (electronic message board) sign.

“He explained their first request was to amend their existing special permit, which prohibited electronic signs, and then they require a special permit under the electronic sign ordinance. At the time the original special permit was granted, it was a different atmosphere with respect to electronic signs. Through the years, the signs have become an essential part of the business for many banks. He described how the bank has become integrated into the neighborhood and has been a good and responsible neighbor to those around them.”

There is no one else speaking in favor. That part of the Public Hearing is closed.

QUESTIONS FROM THE PUBLIC

There are no questions from the public. That part of the Public Hearing is closed.

PUBLIC SPEAKING IN OPPOSITION

There is no one speaking in opposition. That part of the Public Hearing is closed.

QUESTIONS FROM THE CITY COUNCIL

There are no questions from members of City Council. That part of the Public Hearing is closed.

That ends the entire Public Hearing. This is currently in the Urban Affairs Committee.

ADOPTED

ORDER NO. 18/19-1007423C

X 18-1007461B