

CITY OF MARLBOROUGH MEETING POSTING

RECEIVED
CITY CLERK'S OFFICE
CITY OF MARLBOROUGH

Meeting Name: City Council Public Services Committee

Date: May 28, 2019

Time: 7:30 PM (or Immediately following the Conclusion of the Finance Committee Meeting)

2019 MAY 21 P 1:10

Location: City Council Chamber, 2nd Floor, City Hall, 140 Main Street

Agenda Items to be addressed:

1. 04-29-2019 – **Order No. 19-1007651:** Application for Renewal of Junk Dealer/Second Hand Dealer License, Jean Rabelo, d/b/a Post Road Used Auto Parts, 785 Boston Post Road East.
-Refer to Public Services Committee
2. 04-29-2019 – **Order No. 19-1007652:** Application for Renewal of Junk Dealer/Second Hand Dealer License, Gerald Dumais, d/b/a Dumais & Sons Second Hand Store, 65 Mechanic Street.
-Refer to Public Services Committee
3. 04-29-2019 – **Order No. 19-1007653:** Application for Renewal of Junk Dealer/Second Hand Dealer License, Best Buy Stores LP #820, d/b/a Best Buy, 769 Donald J. Lynch Boulevard.
-Refer to Public Services Committee
4. 05-06-2019 – **Order No. 19-1007672:** Petition from TC Systems, Inc., on behalf of AT&T, to install new underground conduits with cable on Forest Street from Pole #24 To Verizon MH #516 for a distance of 65' within the Public Way.
-Refer to Public Services Committee
5. 05-20-2019 – **Order No. 17/19-1007055C:** Communication from Attorney Michael Dolan on behalf of New Cingular Wireless PCS, LLC (AT&T), regarding Small Cell Antenna Petition, 28 Concord Road.
-Refer to Public Services Committee

THE LISTING OF TOPICS THAT THE CHAIR REASONABLY ANTICIPATES WILL BE DISCUSSED AT THE MEETING IS NOT INTENDED AS A GUARANTEE OF THE TOPICS THAT WILL HAVE BEEN DISCUSSED. NOT ALL TOPICS LISTED MAY IN FACT BE DISCUSSED, AND OTHER TOPICS NOT LISTED MAY ALSO BE BROUGHT UP FOR DISCUSSION TO THE EXTENT PERMITTED BY LAW.

The public should take due notice that the Marlborough City Council may have a quorum in attendance due to Standing Committees of the City Council consisting of both voting and non-voting members. However, members attending this duly posted meeting are participating and deliberating only in conjunction with the business of the Standing Committee.

Electronic devices, including laptops, cell phones, pagers, and PDAs must be turned off or put in silent mode upon entering the City Council Chamber, and any person violating this rule shall be asked to leave the chamber. Express authorization to utilize such devices may be granted by the President for recordkeeping purposes.



IN CITY COUNCIL

Marlborough, Mass., APRIL 29, 2019

ORDERED:

That the Application for Renewal of Junk Dealer/Second Hand Dealer License, Jean Rabelo, d/b/a Post Road Used Auto Parts, 785 Boston Post Road East, be and is herewith refer to **PUBLIC SERVICES COMMITTEE.**

ADOPTED

ORDER NO. 19-1007651

10
125
CK # 65039

20



**City of Marlborough, Massachusetts
CITY CLERK DEPARTMENT**

RECEIVED
CITY CLERK'S OFFICE
CITY OF MARLBOROUGH

2019 APR 16 A 9 55

**Lisa M. Thomas
City Clerk**

*Public
Saves*

MARLBOROUGH, MA

DATE: 4/12/19

To the City Council:

Owner Name: Jean Rabelo

Residential Address: 24 Causeway St Hudson MA 01749

Telephone Number: 978-310-7971

Business Name: POST ROAD Used AUTO PARTS of Marlboro, INC

Business Address: 785 BOSTON POST RD

Business Telephone Number: 508-485-1538

Email Address: pruapjes@aol.com

Owner Signature: Jean EC Rabelo

The above-signed Jean Rabelo respectfully requests that he/she be granted a Junk Dealer/Second Hand Dealer License.

In City Council

From: City Council
Sent: Tuesday, May 21, 2019 1:17 PM
To: Don Landers
Cc: Sara Corbin
Subject: Comment from Chief of Police: Updated Junk Dealer CORI Reports on Jean Rabelo-Post Road Used Auto Parts; Kelly Costello-Best Buy; Gerry Dumais-Dumais & Sons Second Hand Store

From: David Giorgi
Sent: Tuesday, May 21, 2019 1:10 PM
To: City Council <citycouncil@marlborough-ma.gov>
Subject: RE: Junk Dealer CORI Reports

Good afternoon Karen,

We do have updated CORI's on each of them, Jean Rabelo, Kelly Costello for Best Buy, and Gerry Dumais, and I do not have any issues with renewing their Junk Dealer's license.

Any questions, please let me know.

D. Giorgi

From: City Council <citycouncil@marlborough-ma.gov>
Sent: Tuesday, May 21, 2019 1:05 PM
To: David Giorgi <dgiorgi@marlborough-ma.gov>
Subject: Junk Dealer CORI Reports

Do you have CORI's on Post Road Used Auto Parts/Jean Rabelo, Best Buy Store, Gerald Dumais.

Thanks.

KB



IN CITY COUNCIL

Marlborough, Mass., APRIL 29, 2019

ORDERED:

That the Application for Renewal of Junk Dealer/Second Hand Dealer License, Gerald Dumais, d/b/a Dumais & Sons Second Hand Store, 65 Mechanic Street, be and is herewith refer to **PUBLIC SERVICES COMMITTEE**.

Councilor Dumais recused.

ADOPTED

ORDER NO. 19-1007652

125
Marysville

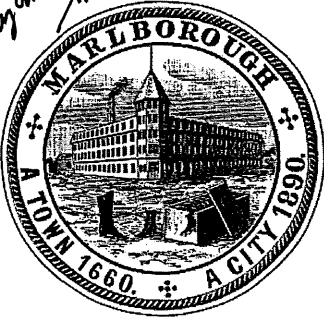

**City of Marlborough, Massachusetts
CITY CLERK DEPARTMENT**

RECEIVED
CITY CLERK'S OFFICE
CITY OF MARLBOROUGH

2019 APR 18 A 10:31

**Lisa M. Thomas
City Clerk**

Public
Services

MARLBOROUGH, MA

DATE: 4/18/19

To the City Council:

Owner Name: GERARD DUMAIS

Residential Address: 6 HIGH STREET MARLBOROUGH MA 01712

Telephone Number: 508-400-4647

Business Name: DUMAIS & SONS SECOND HAND STORE

Business Address: 65 MECHANIC STREET MARLBOROUGH

Business Telephone Number: 508 485-4864

Email Address: DUMAISANDSONS@GMAIL.COM

Owner Signature: *Gerard Dumais*

The above-signed _____ respectfully requests that he/she be
granted a Junk Dealer/Second Hand Dealer License.

In City Council

From: City Council
Sent: Tuesday, May 21, 2019 1:17 PM
To: Don Landers
Cc: Sara Corbin
Subject: Comment from Chief of Police: Updated Junk Dealer CORI Reports on Jean Rabelo-Post Road Used Auto Parts; Kelly Costello-Best Buy; Gerry Dumais-Dumais & Sons Second Hand Store

From: David Giorgi
Sent: Tuesday, May 21, 2019 1:10 PM
To: City Council <citycouncil@marlborough-ma.gov>
Subject: RE: Junk Dealer CORI Reports

Good afternoon Karen,

We do have updated CORI's on each of them, Jean Rabelo, Kelly Costello for Best Buy, and Gerry Dumais, and I do not have any issues with renewing their Junk Dealer's license.

Any questions, please let me know.

D. Giorgi

From: City Council <citycouncil@marlborough-ma.gov>
Sent: Tuesday, May 21, 2019 1:05 PM
To: David Giorgi <dgiorgi@marlborough-ma.gov>
Subject: Junk Dealer CORI Reports

Do you have CORI's on Post Road Used Auto Parts/Jean Rabelo, Best Buy Store, Gerald Dumais.

Thanks.

KB



IN CITY COUNCIL

Marlborough, Mass., APRIL 29, 2019

ORDERED:

That the Application for Renewal of Junk Dealer/Second Hand Dealer License, Best Buy Stores LP #820, d/b/a Best Buy, 769 Donald J. Lynch Boulevard, be and is herewith refer to **PUBLIC SERVICES COMMITTEE.**

ADOPTED

ORDER NO. 19-1007653

22

Pub
#25
ck # 13253575



RECEIVED
City of Marlborough, Massachusetts
CITY CLERK'S OFFICE
CITY OF MARLBOROUGH
CITY CLERK DEPARTMENT

2019 APR 25 A 8:04

Lisa M. Thomas
City Clerk

Public
Swear

MARLBOROUGH, MA

DATE: 4/17/2019

To the City Council:

Owner Name: Best Buy Stores LP #820

Residential Address: PO Box 9450 Minneapolis MN 55440

Telephone Number: 612/291-4863

Business Name: Best Buy Stores LP #820

Business Address: 769 Donald Lynch Blvd, Marlborough, MA 01752

Business Telephone Number: 508-460-3775

Email Address: businesslicense@bestbuy.com

Officer
Owner Signature: *Krist Carlson*

The above-signed Krist Carlson respectfully requests that he/she be
granted a Junk Dealer/Second Hand Dealer License.

In City Council

Marlborough City Clerk's Office ■ 140 Main St. ■ Marlborough, Massachusetts 01752
Telephone (508) 460-3775 ■ Fax (508) 460-3723

CP

From: City Council
Sent: Tuesday, May 21, 2019 1:17 PM
To: Don Landers
Cc: Sara Corbin
Subject: Comment from Chief of Police: Updated Junk Dealer CORI Reports on Jean Rabelo-Post Road Used Auto Parts; Kelly Costello-Best Buy; Gerry Dumais-Dumais & Sons Second Hand Store

From: David Giorgi
Sent: Tuesday, May 21, 2019 1:10 PM
To: City Council <citycouncil@marlborough-ma.gov>
Subject: RE: Junk Dealer CORI Reports

Good afternoon Karen,

We do have updated CORI's on each of them, Jean Rabelo, Kelly Costello for Best Buy, and Gerry Dumais, and I do not have any issues with renewing their Junk Dealer's license.

Any questions, please let me know.

D. Giorgi

From: City Council <citycouncil@marlborough-ma.gov>
Sent: Tuesday, May 21, 2019 1:05 PM
To: David Giorgi <dgiorgi@marlborough-ma.gov>
Subject: Junk Dealer CORI Reports

Do you have CORI's on Post Road Used Auto Parts/Jean Rabelo, Best Buy Store, Gerald Dumais.

Thanks.

KB



IN CITY COUNCIL

Marlborough, Mass., MAY 6, 2019

ORDERED:

That there being no objection thereto set **MONDAY MAY 20, 2019** as **DATE FOR PUBLIC HEARING** on the Petition from TC Systems, Inc., on behalf of AT&T, to install new underground conduits with cable on Forest Street from Pole #24 To Verizon MH #516 for a distance of 65' within the Public Way, be and is herewith refer to **PUBLIC SERVICES COMMITTEE.**

ADOPTED

ORDER NO. 19-1007672

TC SYSTEMS, INC.

A Wholly Owned Subsidiary of  at&t

157 Green Street, Suite 2
Foxboro, MA 02035

RECEIVED
CITY CLERK'S OFFICE
CITY OF MARLBOROUGH
2019 MAY -1 P 3:40

May 1, 2019
To the City Council of Marlborough
140 Main Street,
Marlborough Massachusetts 01752

Re: PETITION FOR GRANT OF LOCATION – FOREST STREET

Dear Members of the City Council:

On behalf of TC Systems, Inc, a wholly owned subsidiary of AT&T Corp, Giomare Group LLC is hereby requesting from the City of Marlborough, permission to lay, maintain and operate underground conduits, with the cables to be placed therein, under the surface of the following way:

Forest Street, from utility pole #24 to Verizon MH #516 for a distance of approximately 65'.

All conduits to be placed at a depth of approximately 36" and in accordance with the requirements of the City's Department of Public Works.

Fourteen (14) sets of plans entitled "TC Systems, Inc. Proposed Conduit Placement Plan Forest Street, Marlborough, MA April 02, 2019" are filed herewith. Your consideration of this petition is greatly appreciated and we look forward to discussing the project with you at the next available public hearing.

Sincerely,

Giomare Group LLC

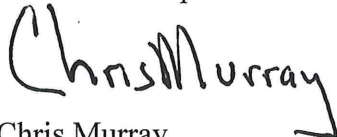

Chris Murray
Engineering Manager

TC SYSTEMS, INC.

A Wholly Owned Subsidiary of  at&t

157 Green Street, Suite 2
Foxboro, MA 02035

PETITION FOR GRANT OF LOCATION

To the City Council of
Marlborough, Massachusetts

TC Systems, Inc. requests permission to locate underground conduits, structures and fixtures, including the necessary sustaining and protecting fixtures, along and across the following public way:

TC Systems Inc proposes to construct (1) 4" PVC conduit approximately 65' from utility pole #24 to Verizon MH #516 at a depth of approximately 36" on Forest Street, Marlborough.

Location approximately as shown on plan attached entitled "TC Systems, Inc. Proposed Conduit Placement Plan Forest Street, Marlborough, MA April 02, 2019".

Also for permission to lay and maintain underground laterals, cables, and wires in the above or intersecting public ways for the purpose of making connections with such poles and buildings as each of said petitioners may desire for distributing purposes.

BY 
Engineering Manager

®

TC SYSTEMS, INC.

A Wholly Owned Subsidiary of  at&t

157 Green Street, Suite 2
Foxboro, MA 02035

TC Systems Inc.
157 Green Street, Suite 2
Foxboro, MA 02035
Tel: 508.216.0033
Fax: 508.216.0068

January 1,
2019

To: The Town of Marlborough, Massachusetts

RE: TC Systems, Inc., a Delaware corporation
Letter of Agency
On behalf of GioMare Group LLC
51 Webb Place Dover NH, 03820

To whom it may concern:

On behalf of TC Systems, Inc., a wholly owned subsidiary of AT&T Corp., this letter shall serve as notice that TC Systems has retained the services of GioMare Group LLC (GioMare) to act on behalf of TC Systems in the conduct of various network projects in the New England area.

In that regard, TC Systems hereby authorizes employees of GioMare to act as TC Systems agent in the following capacity: all responsibilities needed to obtain permits, licenses and license agreements, both aerial and underground.

Should you have any concerns regarding this letter of the role GioMare Group, please contact me at (508) 216-0033 or rs3757@att.com.

Sincerely,



Richard Solitro
OSP Manager
TC Systems, Inc.

TC SYSTEMS INC.
 PROPOSED CONDUIT PLACEMENT PLAN
 FOREST STREET, MARLBOROUGH, MA
 APRIL 02, 2019

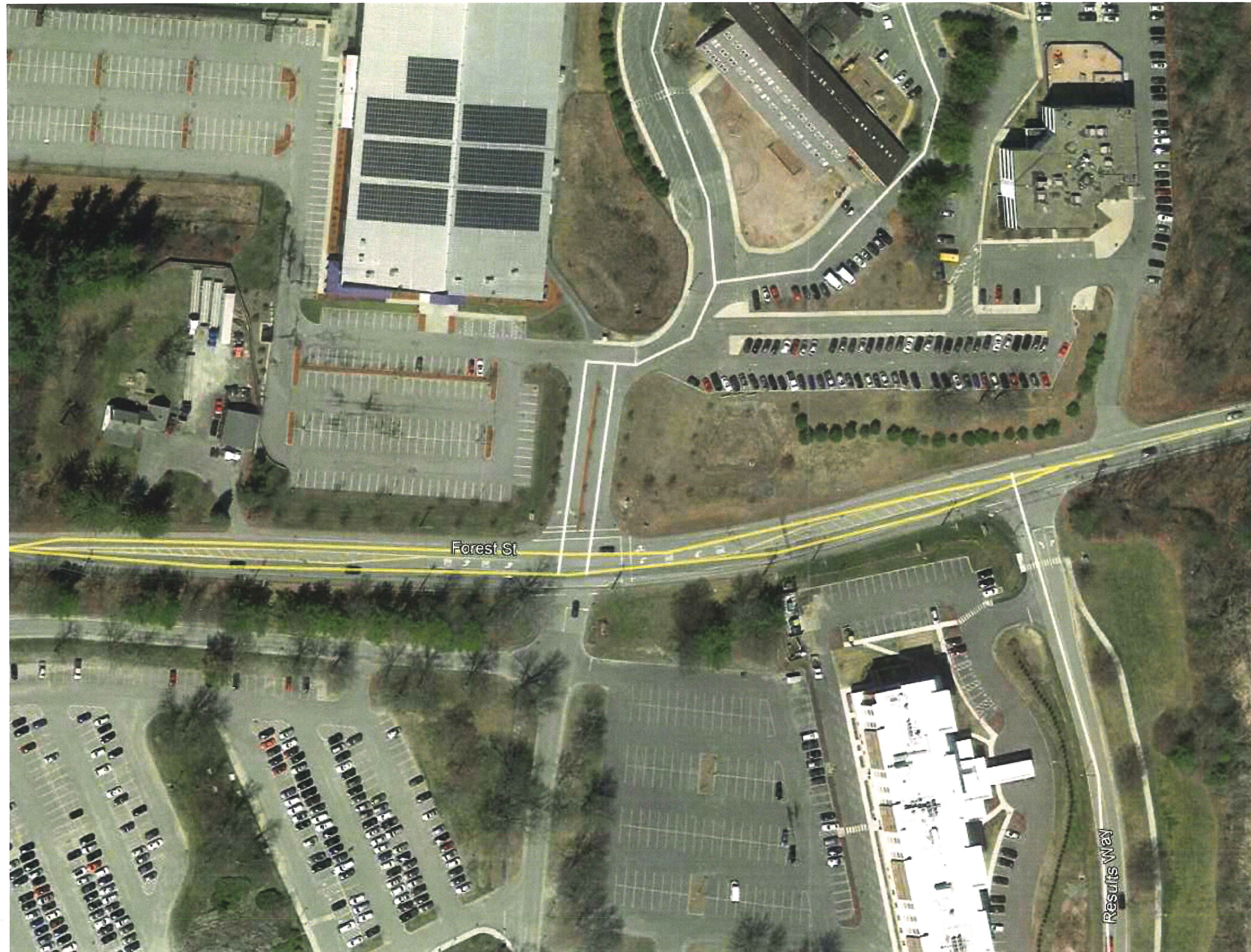

PREPARED FOR

TC SYSTEMS, INC.

A Wholly Owned Subsidiary of at&t

157 Green Street, Suite 2
 Foxboro, MA 02035

SITE INDEX

- 1 - COVER SHEET
- 2 - LEGEND AND NOTES
- 3 - SITE PLAN
- 4 - DETAILS

CONTACTS

NAME: JEREMY LEAVITT
 COMPANY: GIOMARE GROUP LLC
 TITLE: OSP PROJECT MANAGER
 PHONE: 603-970-0077

3				AS-BUILT
2				REVISION # 1
1	4-02-2019	JJL	NMT	ORIGINAL
NO.	DATE	ENG DESIGN	DRAFTING	COMMENT

GIOMARE GROUP, LLC

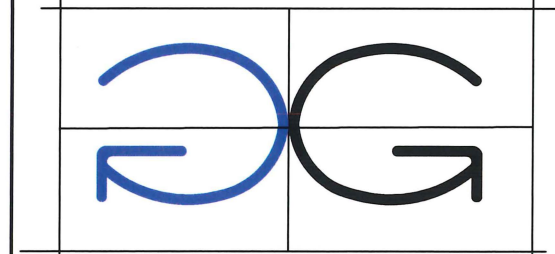

TELECOM CONSULTING & ENGINEERING

GIOMARE GROUP, LLC ENGINEER: JEREMY LEAVITT
 CUSTOMER NAME: QUEST DIAGNOSTICS
 PROJECT NUMBER: 2019-60501
 LOCATION: 200 FOREST STREET
 MARLBOROUGH, MA
 DRAWING NAME: 200 Forest Street, Proposed Conduit Placement Plan
 CONFIDENTIAL/PROPRIETARY SHEET: 1 OF 4



Call Before You Dig
 1-888-DIG-SAFE

PREPARED FOR

TC SYSTEMS, INC.

A Wholly Owned Subsidiary of 

157 Green Street, Suite 2
Foxboro, MA 02035

CONTACTS

NAME: JEREMY LEAVITT
COMPANY: GIOMARE GROUP LLC
TITLE: OSP PROJECT MANAGER
PHONE: 603-970-0077

NOTES:

- SUBSURFACE UTILITY LINES, AS SHOWN HEREON, WERE COMPILED ACCORDING TO AVAILABLE RECORD INFORMATION FROM THE REFERENCED COMPANIES AND PUBLIC AGENCIES, AND THEIR LOCATIONS ARE APPROXIMATE ONLY. ACTUAL LOCATIONS MUST BE DETERMINED IN THE FIELD. GIOMARE GROUP ASSUMES NO RESPONSIBILITY FOR DAMAGES INCURRED AS A RESULT OF UTILITIES OMITTED OR INACCURATELY SHOWN.
- PROPERTY OWNERS AND PARCEL IDENTIFIERS ARE ACCORDING TO THE TOWN OF MARLBOROUGH ASSESSORS ON-LINE PARCEL DATA, [HTTPS://WWW.AXISGIS.COM/MARLBOROUGHMA/](https://www.axisgis.com/marlboroughma/)
- ALL WORK CONFORMED TO TOWN OF NEEDHAM SPECIFICATIONS, AS WELL AS, CONSTRUCTION DETAILS, INCLUDING MATERIALS AND CONSTRUCTION METHODS.
- ALL SURFACE FEATURES WERE RESTORED TO PRE CONSTRUCTION CONDITIONS.

3				AS-BUILT
2				REVISION # 1
1	4-02-2019	JJL	NMT	ORIGINAL
NO.	DATE	ENG DESIGN	DRAFTING	COMMENT

GIOMARE GROUP, LLC

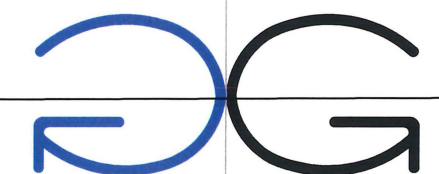

TELECOM CONSULTING & ENGINEERING

GIOMARE GROUP, LLC ENGINEER: JEREMY LEAVITT
CUSTOMER NAME: QUEST DIAGNOSTICS
PROJECT NUMBER: 2019-60501
LOCATION: 200 FOREST STREET
MARLBOROUGH, MA

DRAWING NAME: 200 Forest Street, Proposed Conduit Placement Plan
CONFIDENTIAL/PROPRIETARY SHEET: 2 OF 4

LEGEND

B/P	BEANPOLE
STK/TK	STAKE/TACK
PK	PK NAIL
SB/DH	STONE BOUND/DRILL HOLE
FND	FOUND
N/F	NOW OR FORMERLY
W/	WITH
— X —	FENCE(TYPE)
CLF	CHAIN LINK FENCE
====	CURBING(TYPE)
BIT CONC	BITUMINOUS CONCRETE
GRAN	GRANITE
⊙ GP	GUARD POST (BOLLARD)
●	SIGN
○ PM	PM
□ GHH	GAS HANDHOLE
□ EHH	ELECTRIC HANDHOLE
○/□ HH	HANDHOLE
● LP	LIGHT POLE
⊙ DMH	DRAIN MANHOLE
□ CB	CATCH BASIN
○ GG	GAS GATE
⊙ CMH	CABLE TELEVISION MANHOLE
⊙ EMH	ELECTRIC MANHOLE
⊙ SMH	SEWER MANHOLE
⊙ STMH	STEAM MANHOLE
⊙ TMH	TELEPHONE MANHOLE
⊙ GMH	GAS MANHOLE
○ WG	WATER GATE
⊙ MW	MONITORING WELL
⊙	HYDRANT
□ BWW	BOSTON WATER WORKS HANDHOLE
⊗ TSCC	TRAFFIC SIGNAL CONTROL CABINET

○ UP

○ TS

▶

□ MB

⊙ 4"D

●

(ABAN)

(R)

CONC

SW

HPFS MH

CIP

PVC

ELEC

HCAP

LST

— W —

— S —

— CATV —

— T —

— E —

— D —

— G —

— CS —

— ST —

— L(3) —

— RCN —

— MCI —

— MBTA —

—

—

UTILITY POLE

TRAFFIC SIGNAL

TRAFFIC MAST ARM

MAILBOX

DECIDUOUS TREE, 4 IN. DIA (TYPICAL)

BICYCLE RACK

ABANDONED

RECORD

CONCRETE

SIDEWALK

HIGH PRESSURE FIRE SERVICE MANHOLE

CAST IRON PIPE

POLYVINYL CHLORIDE

ELECTRIC

HANDICAP

LANDSCAPE TIMBER

WATER LINE

SEWER LINE

CABLE TELEVISION

TELEPHONE LINE

ELECTRIC LINE

DRAIN LINE

GAS LINE

COMBINED SEWER LINE

STEAM LINE

LEVEL(3)

RCN

MCI

MASSACHUSETTS BAY TRANSPORTATION AUTHORITY

EDGE OF PAVEMENT

TC SYSTEMS, INC. CONDUITS

ASW

BIP

BSP

CSW

EOP

EOTW

FOC

HDPE

HH

JB

MH

MP

O/S

PVC

RGS

ROW

STA.

ASPHALT SIDEWALK

BLACK IRON PIPE

BLACK STEEL PIPE

CONCRETE SIDEWALK

EDGE OF PAVEMENT

EDGE OF TRAVEL WAY

FACE OF CURB

HIGH DENSITY POLYETHYLENE

HANDHOLE

JUNCTION BOX

MANHOLE

MILE POST

OFFSET

POLY VINYL CHLORIDE

RIGID GALVANIZED STEEL CONDUIT

RIGHT OF WAY

STATION



Call Before You Dig
1-888-DIG-SAFE

PREPARED FOR

TC SYSTEMS, INC.

A Wholly Owned Subsidiary of  at&t

157 Green Street, Suite 2
Foxboro, MA 02035

CONTACTS

NAME: JEREMY LEAVITT
COMPANY: GIOMARE GROUP LLC
TITLE: OSP PROJECT MANAGER
PHONE: 603-970-0077

219 FOREST STREET
MARLBOROUGH, MA
PARCEL ID: 90-2

199-201 FOREST STREET
MARLBOROUGH, MA
PARCEL ID: 90-2C

200-230 FOREST STREET
MARLBOROUGH, MA
PARCEL ID: 101-2

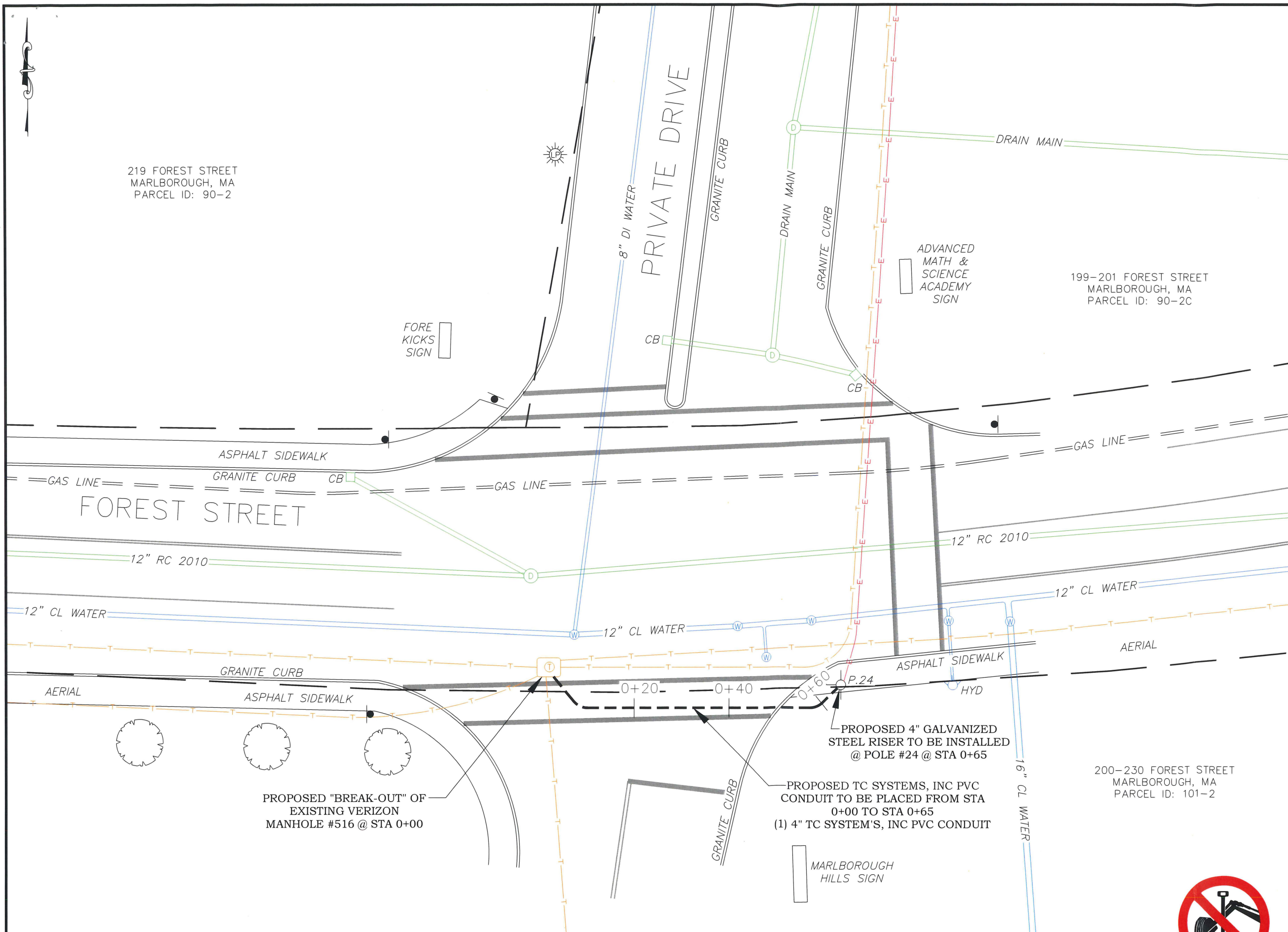

3				AS-BUILT
2				REVISION # 1
1	4-02-2019	JJL	NMT	ORIGINAL
NO.	DATE	ENG DESIGN	DRAFTING	COMMENT

GIOMARE GROUP, LLC

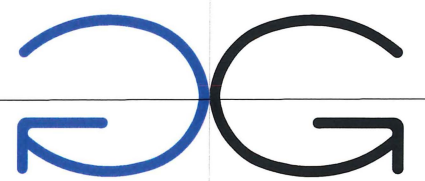

TELECOM CONSULTING & ENGINEERING

GIOMARE GROUP, LLC ENGINEER: JEREMY LEAVITT
 CUSTOMER NAME: QUEST DIAGNOSTICS
 PROJECT NUMBER: 2019-60501
 LOCATION: 200 FOREST STREET
 MARLBOROUGH, MA
 DRAWING NAME: 200 Forest Street, Proposed Conduit Placement Plan
 4-1-2019.dwg
 CONFIDENTIAL/PROPRIETARY SHEET: 3 OF 4



Call Before You Dig
1-888-DIG-SAFE

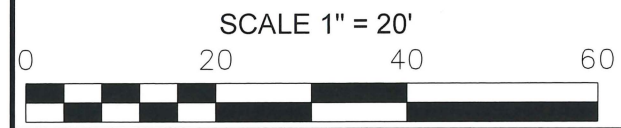

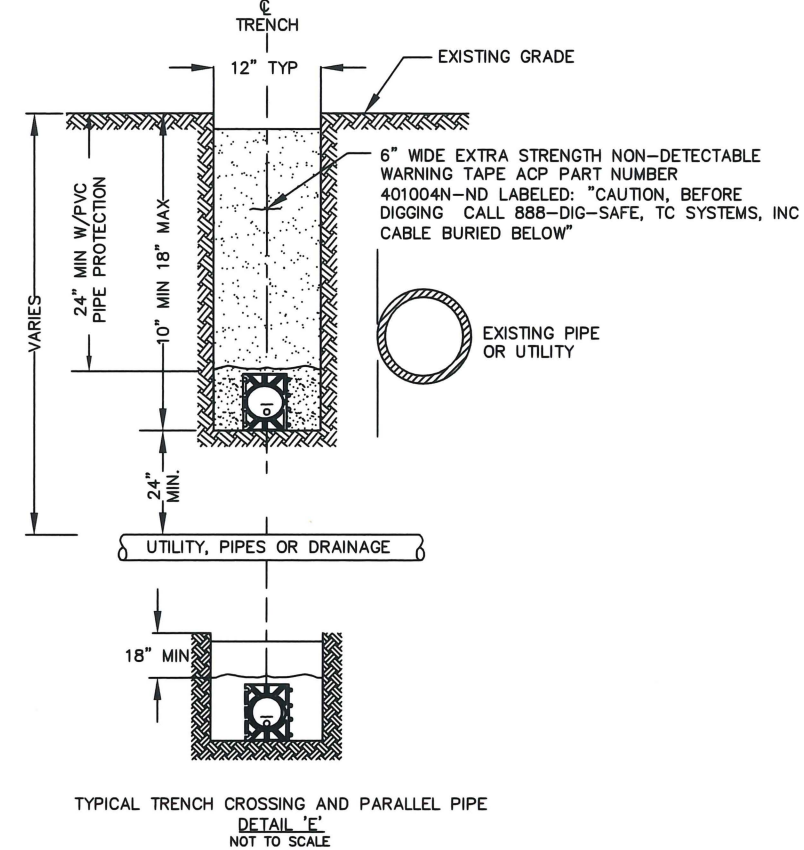
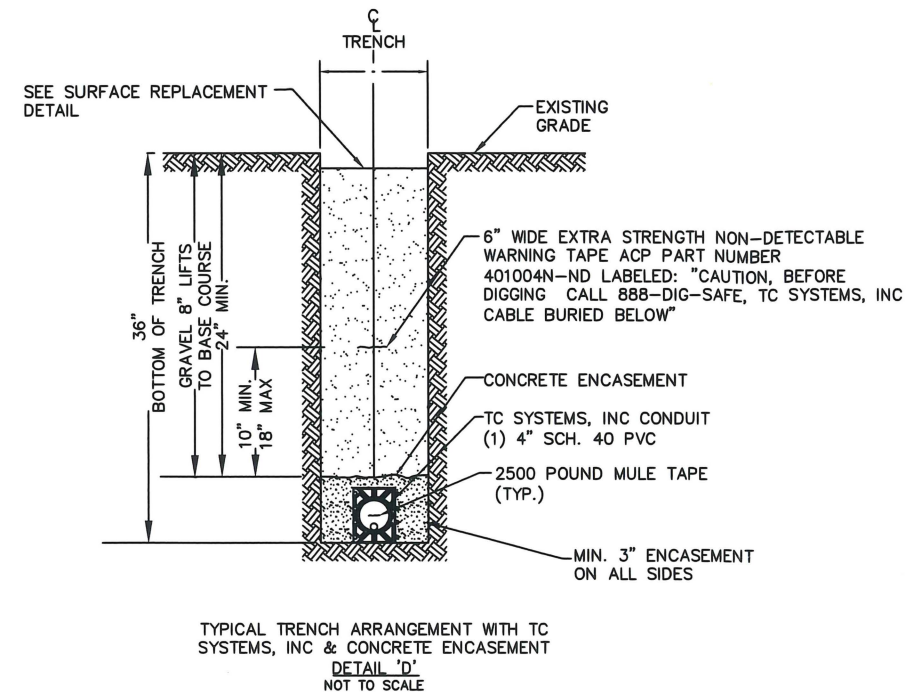
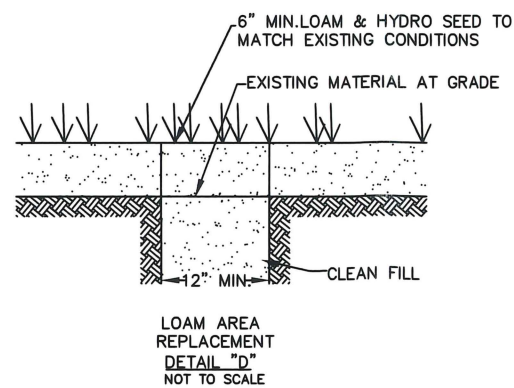
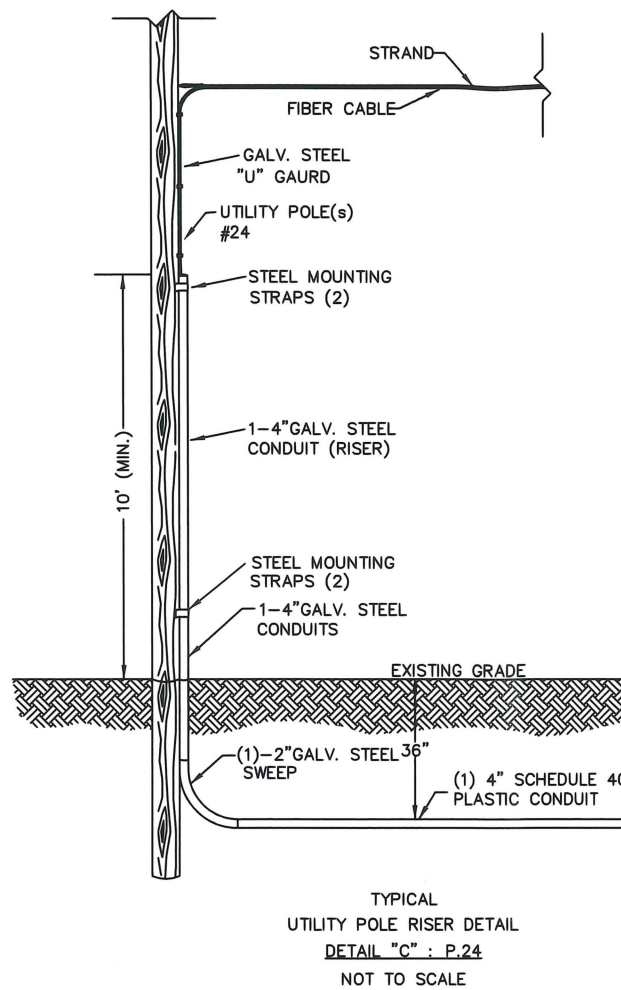
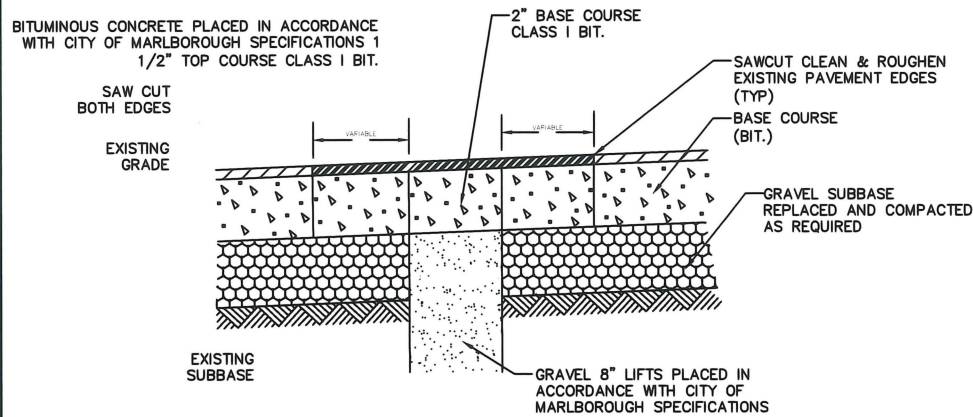
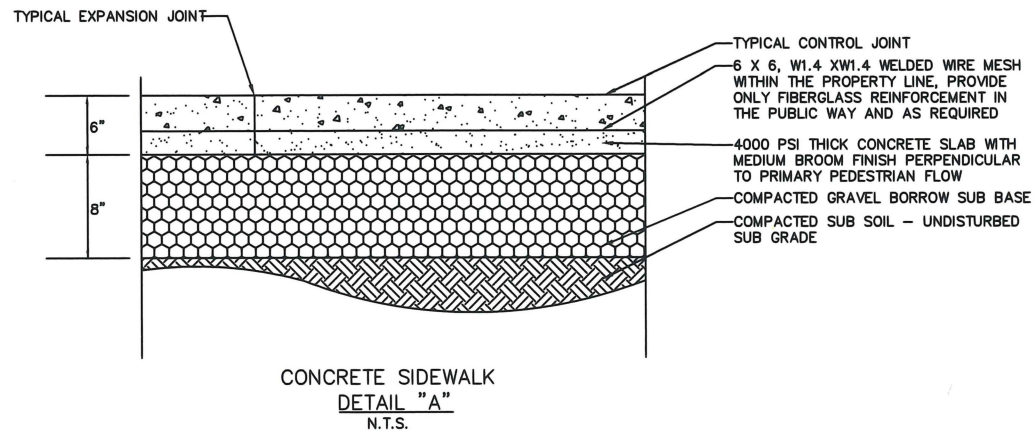

Call Before You Dig
1-888-DIG-SAFE

PREPARED FOR

TC SYSTEMS, INC.

A Wholly Owned Subsidiary of at&t

157 Green Street, Suite 2
Foxboro, MA 02035

3				AS-BUILT
2				REVISION # 1
1	4-02-2019	JJL	NMT	ORIGINAL
NO.	DATE	ENG DESIGN	DRAFTING	COMMENT

GIOMARE GROUP, LLC

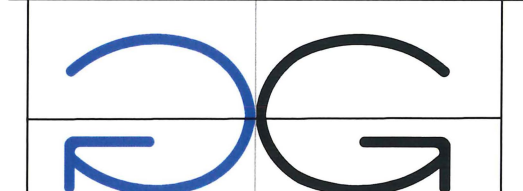

TELECOM CONSULTING & ENGINEERING

GIOMARE GROUP, LLC ENGINEER: JEREMY LEAVITT

CUSTOMER NAME: QUEST DIAGNOSTICS

PROJECT NUMBER: 2019-60501

LOCATION: 200 FOREST STREET

MARLBOROUGH, MA

DRAWING NAME: 200 Forest Street, Proposed Conduit Placement Plan

CONFIDENTIAL/PROPRIETARY

SHEET: 4 OF 4



IN CITY COUNCIL

Marlborough, Mass., _____ MAY 20, 2019

ORDERED:

That the Communication from Attorney Michael Dolan on behalf of New Cingular Wireless PCS, LLC (AT&T), re: Small Cell Antenna Petition, 28 Concord Road, be and is herewith **REMOVED** from the **WIRELESS COMMUNICATIONS COMMITTEE** and be and is herewith refer to **PUBLIC SERVICES COMMITTEE**.

ADOPTED

ORDER NO. 17/19-1007055C

RECEIVED
CITY CLERK'S OFFICE
CITY OF MARLBOROUGH

May 7, 2019

2019 MAY -9 P 2:00

16
*Remove from Wireless
to
Public Services*

VIA EMAIL AND OVERNIGHT DELIVERY

City Council President Edward J. Clancy
Marlborough City Council
140 Main Street
Marlborough, MA 01752

Re: New Cingular Wireless PCS, LLC ("AT&T") Small Cell Antenna Petition - 28
Concord Road (Order No. 17-1007055)

Dear Honorable President Clancy and City Councilors:

You will recall that the last of AT&T's Small Cell Antenna applications (28 Concord Road) is still pending with the Wireless Committee and that the remaining action item for AT&T from the Committee at the last meeting was that AT&T needed to work with NGrid to produce a structural analysis demonstrating that the subject pole is capable of holding AT&T's proposed equipment. The existing pole is leaning considerably.

After many discussions with NGrid, my client has been advised by NGrid that they will actually replace the existing pole with a new pole to address the structural concerns. It will also improve the appearance of the existing pole which currently tilts so much as to be aesthetically unpleasing. Enclosed herewith is a copy of the plans for the new pole with the proposed AT&T equipment thereon. As with AT&T's other approved installations and per the request of the City Council, all of AT&T's equipment will be at least 11' off the ground on the new pole.

NGrid is requiring that AT&T pay for the installation of the new pole and as such AT&T is seeking to first secure an approval from the City Council for its proposed antenna facility before it gives the go-ahead to NGrid to install the new pole. It is my understanding that Small Cell Antenna applications are now considered by the Public Services Committee as opposed to the Wireless Committee and, as such, AT&T respectfully requests that its updated Petition be placed on the agenda of the next Public Services Committee meeting.

Thank you for your consideration, and do not hesitate to contact me if you have any questions.

Respectfully,

BROWN RUDNICK LLP

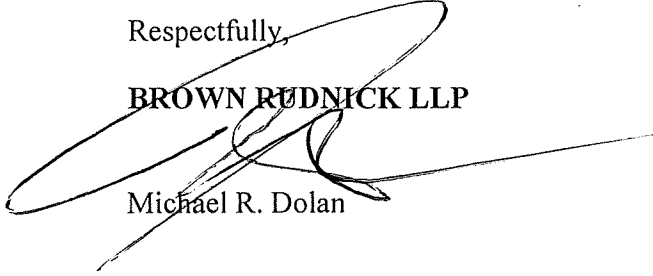

Michael R. Dolan

MRD/sad

cc: Donald V. Rider, Jr., Esq. (email only)

63394572 v1-WorkSiteUS-024519/1016

APPROXIMATE COORDINATES: LAT: 42.352556° N
LONG: 71.529969° W

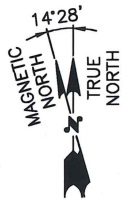
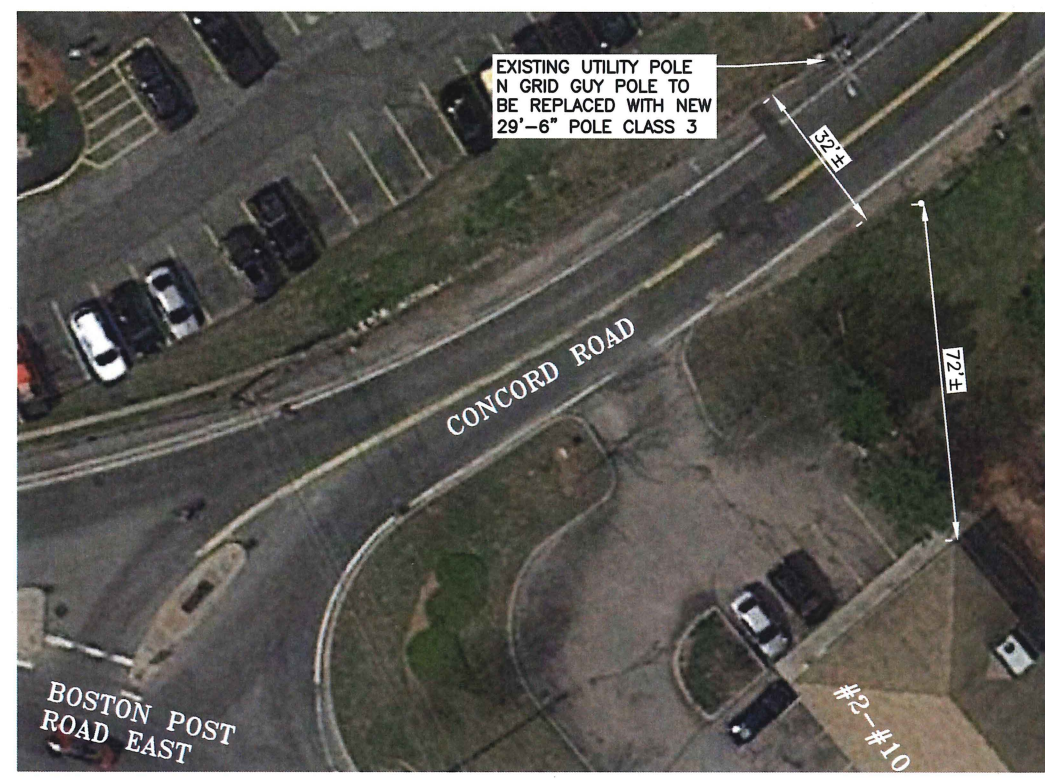

KEY PLAN
22x34 SCALE: 1"=20'
11x17 SCALE: 1"=40'

GRAPHIC SCALE
0 10 20 40 60 FEET



EXISTING CONDITIONS PHOTO DETAIL
SCALE: N.T.S.

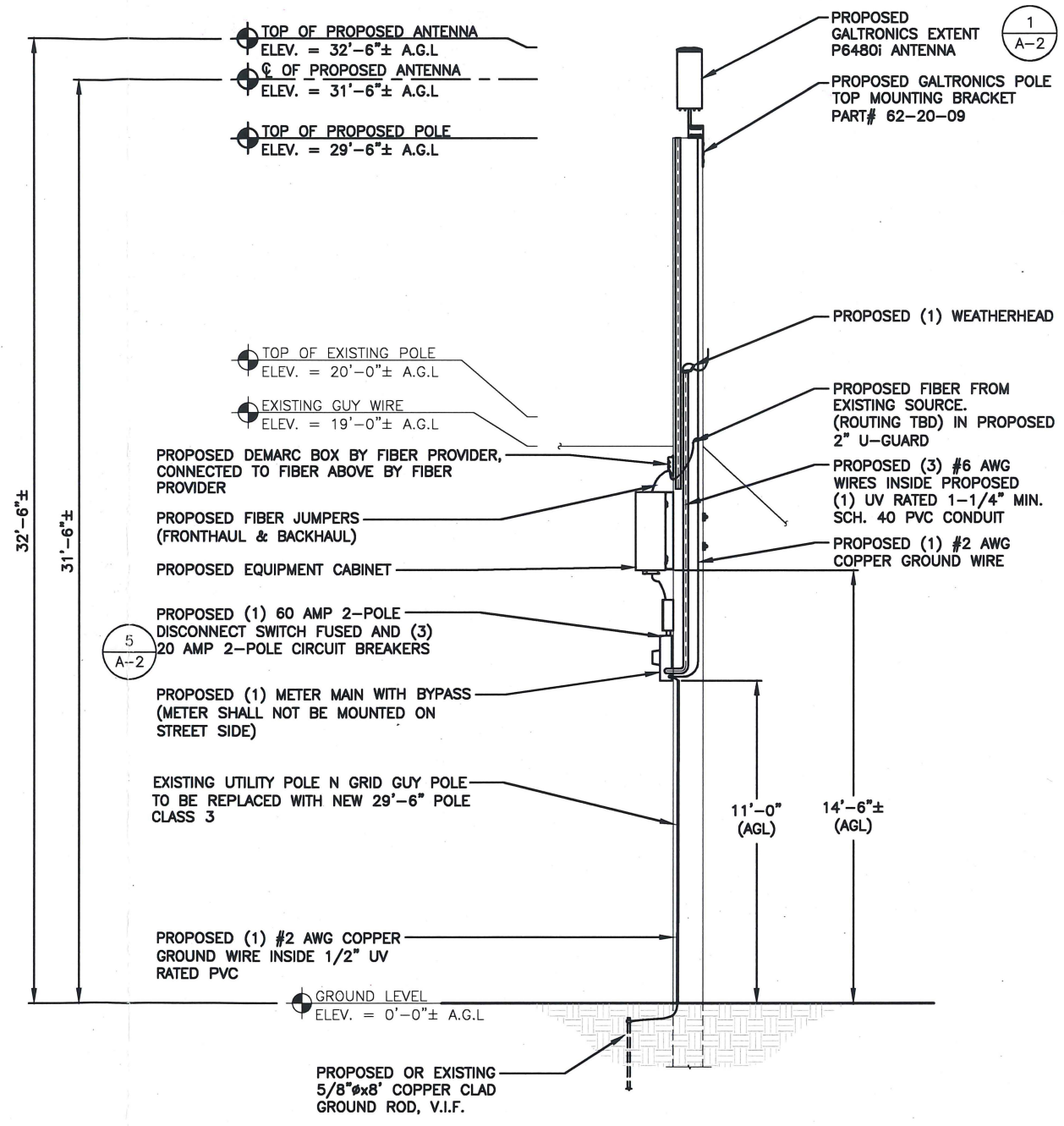

ELEVATION
22x34 SCALE: 3/8"=1'-0"
11x17 SCALE: 3/16"=1'-0"

GRAPHIC SCALE
0 1'-4" 2'-8" 5'-4" 8'-0"

CHECKED BY: AT

APPROVED BY: DJC

SUBMITTALS

REV.	DATE	DESCRIPTION	BY
3	04/18/19	REVISED PER COMMENTS	MR
2	04/16/19	REVISED PER COMMENTS	MR
1	10/01/17	REVISED PER COMMENTS	SB
0	08/02/17	ISSUED FOR REVIEW	SB

CLUSTER AND NODE NUMBER:
AREA 5_87A

SITE ID:
AREA 5_87A

SITE ADDRESS:
28 CONCORD ROAD
MARLBOROUGH, MA 01752
MIDDLESEX COUNTY

SHEET TITLE
KEY PLAN AND ELEVATION

SHEET NUMBER
A-1

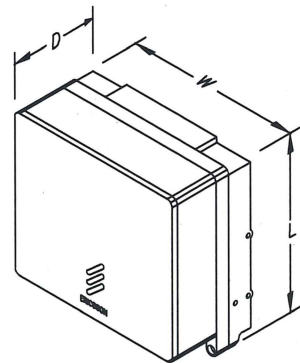
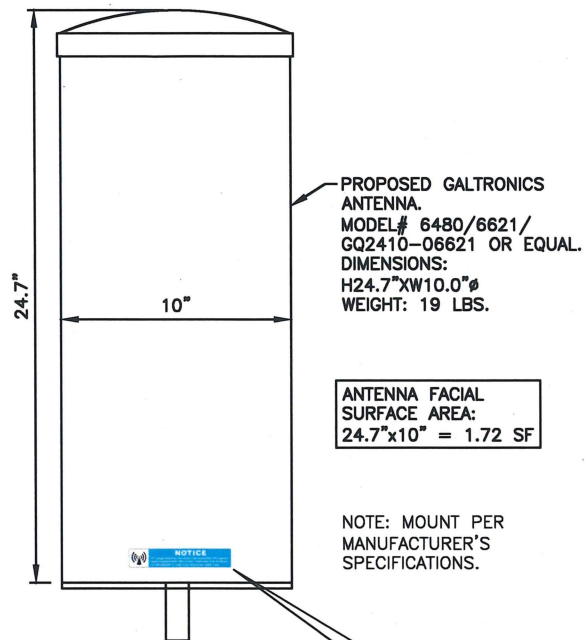

MODEL	QTY	L	W	D	WGT.
2203	2	8.0"	8.0"	4.0"	11 LB
2205	1	8.0"	8.0"	4.0"	11 LB

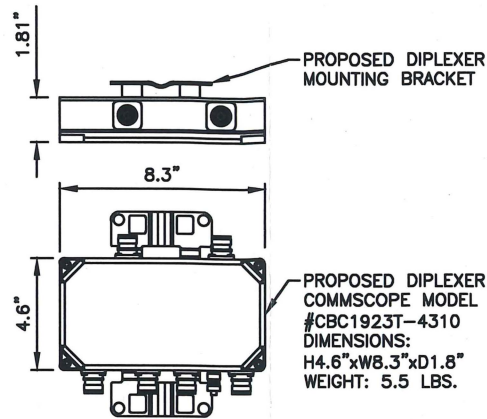

RRH DETAIL

SCALE: N.T.S

2
A-2

DIPLEXER DETAIL (AS REQUIRED)

SCALE: N.T.S

3
A-2



NO1-CD-16 1"x6" NOTICE DECAL
PLACE THREE NOTICE STICKERS EQUALLY SPACED AROUND THE BOTTOM OF ANTENNA RADOME

ANTENNA DETAIL

SCALE: N.T.S

1
A-2

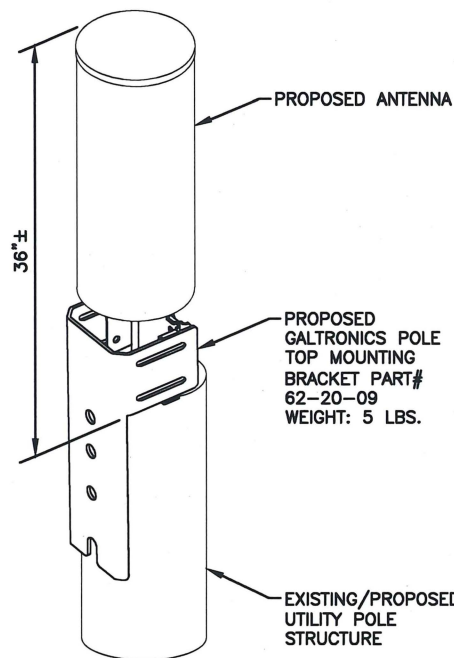

ANTENNA MOUNT DETAIL

SCALE: N.T.S

4
A-2

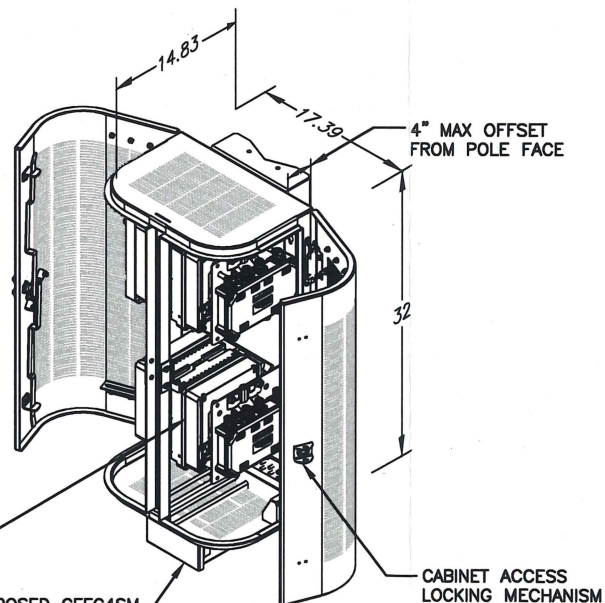

NO BATTERY BACKUP OR AUXILIARY OUTLETS FOR BACKUP POWER ARE BEING PROVIDED IN THIS DESIGN

NOTE: MOUNT PER MANUFACTURER'S SPECIFICATIONS.

EQUIPMENT CABINET DETAIL

SCALE: N.T.S

5
A-2

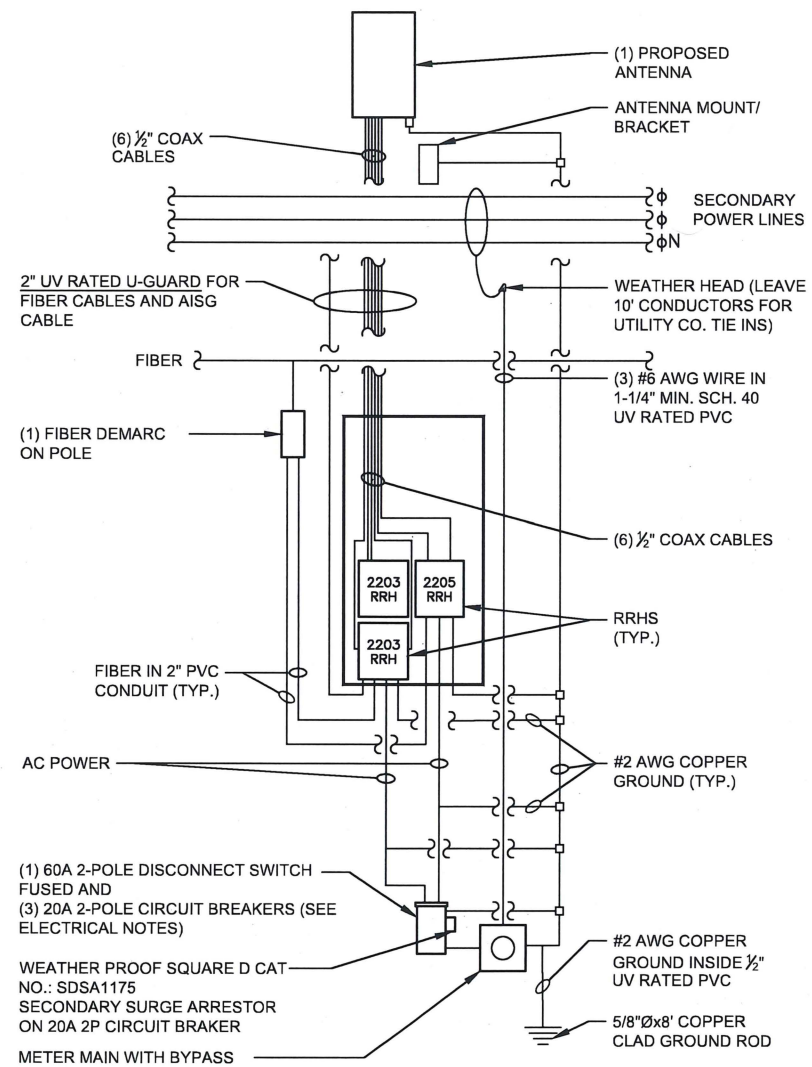

GENERAL WIRING DIAGRAM

SCALE: N.T.S

6
A-2



CHECKED BY: AT

APPROVED BY: DJC

SUBMITTALS			
REV.	DATE	DESCRIPTION	BY
3	04/18/19	REVISED PER COMMENTS	MR
2	04/16/19	REVISED PER COMMENTS	MR
1	10/01/17	REVISED PER COMMENTS	SB
0	08/02/17	ISSUED FOR REVIEW	SB

CLUSTER AND NODE NUMBER:
AREA 5_87A

SITE ID:
AREA 5_87A

SITE ADDRESS:
28 CONCORD ROAD
MARLBOROUGH, MA 01752
MIDDLESEX COUNTY

SHEET TITLE
EQUIPMENT DETAILS

SHEET NUMBER
A-2